

The Harman Kardon Model HD7500 COMPACT DISC PLAYER

Manual 153A

Technical Manual

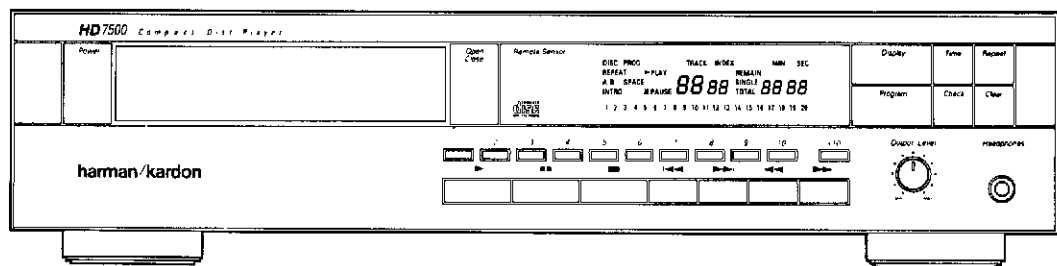

The following marks found in the parts list of this manual identify the models as follows.

- **UA** : North America area model
- **BK** : North America area model Black version
- **I** : International model
- **IB** : International model Black version
- **NE** : Japan model Black version
- **BE** : Australia model Black version

HD7500

harman/kardon

240 Crossways Park West, Woodbury, N. Y. 11797
1112-3152153A6 P-118906 1500 Printed in Japan

CLASS 1 LASER PRODUCT

Product complies with DHHS rules CFR subchapter J part 1040:10 at date of manufacture.

DANGER—invisible laser radiation when open and interlock failed or defeated. Avoid direct exposure to the beam.

CAUTION—use of all controls, adjustments or performance of procedures other than those specified herein may result in hazardous radiation exposure.



Be Careful of the Laser Pickup

Although you cannot see it from the outside, a laser pickup is located under the disc tray and a precision lens is built in it.

Since the laser pickup, including the lens element, is especially sensitive to dust, keep the disc tray closed when not in use. Also do not put your hand inside the unit.

ADVARSEL:

Usynlig laserstråling ved åbning når sikkerhedsafbrydere er ude af funktion. Undgå udsættelse for stråling.

VAROITUS!

Laite sisältää laserdiodin, joka lähettää näkymätöntä silmille vaarallista lasersäteilyä.

SPECIFICATION

System : Compact Disc Digital Audio
 D/A Converter : Linear, Pulse Width Modulated Bit Stream, Clock Rate: 33.8688MHz (33,868.8KHz)
 Signal Detection : 3-Beam Semiconductor Optical Laser Pickup
 Error Correction : CIRC System
 Low Level Linearity : +/-0.2dB @-90dB
 Frequency Response : 4Hz to 20kHz +0dB/-5dB
 Total Harmonic Distortion (THD) : 0.003%
 Dynamic Range : 98dB
 Signal to Noise Ratio : 106dB

Channel Separation : 96dB
 Line Output Level/ Impedance : 2.0V @ 10kΩ
 Power Supply
 U.S.A. and Canada models : AC120V, 60Hz
 International model : AC220/240V, 50/60Hz
 Japan model : AC100V, 50/60Hz
 Power Consumption : 20Watts (Japan model: 17Watts)
 Dimensions : 17-3/8" x 4" x 14"
 443mm x 103mm x 356 mm
 Weight : 11.9lb/5.4kg

Specifications and components subject to change without notice. Overall performance will be maintained or improved.

Adjustment of this unit requires following measuring instruments and jigs.

- Oscilloscope (3 or more modes, 100MHz, input Select DC range) 1740A
- Test Disc : EIAJ CD-1

TROUBLE SHOOTING

When a trouble has occurred, first check the pick-up lens for dirt and each connector for tight and secure connection. If the problem persists after checking both of these items, use the following check procedures.

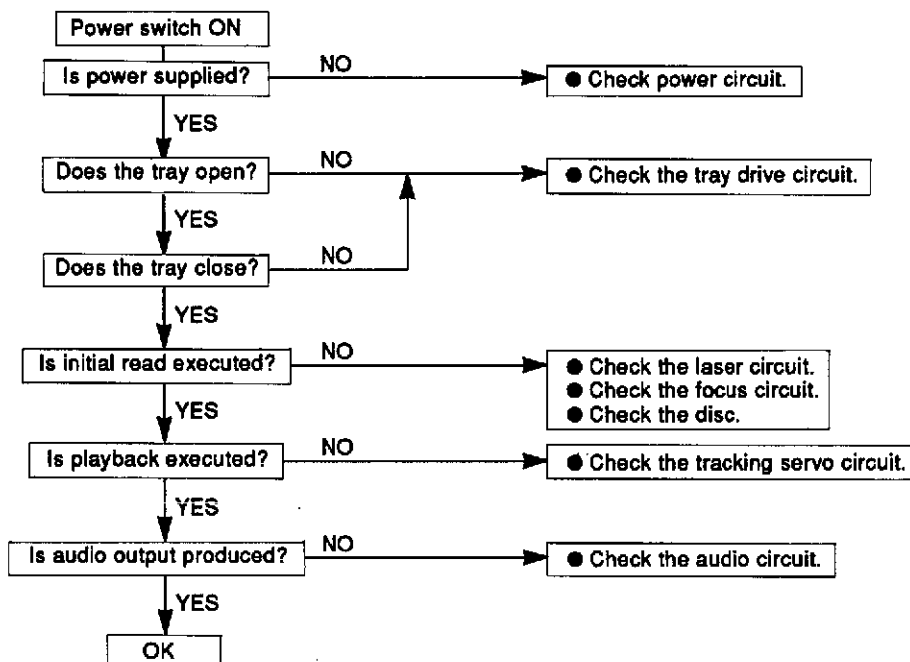

(1) When Multi Display fails to light properly

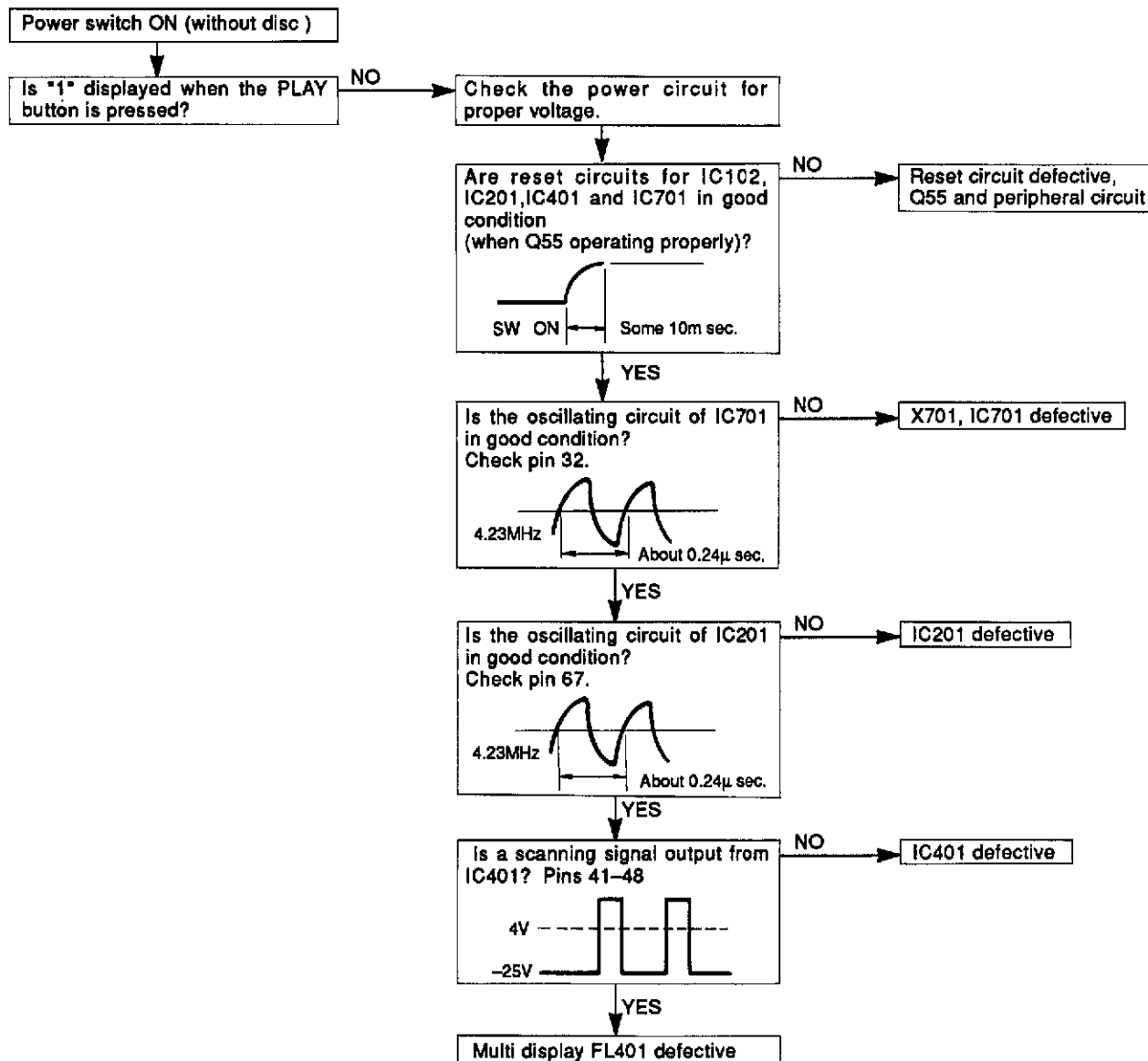

General Servicing Precautions

- a. Always unplug the instrument AC power cord from the AC power source before:
 - (1) Removing or reinstalling any component, circuit board, module, or any other instrument assembly.
 - (2) Disconnecting or reconnecting any instrument electrical plug or other electrical connection.
 - (3) Connecting a test substitute in parallel with an electrolytic capacitor in the instrument.

Caution: A wrong part substitution or incorrect polarity installation of electrolytic capacitors may result in an explosion hazard.
- b. Do **not** defeat any plug/socket B+ voltage interlocks with which instruments covered by this manual might be equipped.
- c. Do **not** apply AC power to this instrument and/or any of its electrical assemblies unless all solid-state device heat sinks are correctly installed.
- d. Always connect a test instrument's ground lead to the instrument chassis ground before connecting the test instrument positive lead. Always remove the test instrument ground lead last.

NOTE: Refer to Safety Precautions on Page 3.

- (1) The service precautions are indicated or printed on the cabinet, chassis or components. When servicing, follow the printed or indicated service precautions and service materials.
- (2) The Components used in the unit has a specified conflammability and dielectric strength. When replacing any components, use components which has the same ratings. Components marked (Δ) in the circuit diagram are important for safety or for the characteristics of the unit. Always replace with the appointed components.
- (3) An insulation tube or tape is sometimes used and some components are raised above the printed wiring board for safety. The internal wiring is sometimes clamped to prevent contact with heating components. Install them as they were.
- (4) After servicing, always check that the removed screws, components and wiring have been installed correctly and that the portion around the service part have not been damaged and so on. Further check the insulation between the blades of attachment plug and accessible conductive parts.

Insulation Checking Procedure

Disconnect the attachment plug from the AC outlet and turn the power on. Connect the insulation resistance meter (500V) to the blades of the attachment plug. The insulation resistance between the each blade of the attachment plug and accessible conductive parts (Note 1) should be more than 1M-ohm.

Note 1: Accessible Conductive Parts including Metal panels, Output jacks, etc.

ELECTROSTATICALLY SENSITIVE (ES) DEVICES

Some semiconductor (solid state) devices can be damaged easily by static electricity. Such components commonly are called Electrostatically Sensitive (ES) Devices. Examples of typical ES devices are integrated circuits and some field-effect transistors and semiconductor "chip" components. The following techniques should be used to help reduce the incidence of component damage caused by static electricity.

1. Immediately before handling any semiconductor component or semiconductor-equipped assembly, drain off any electrostatic charge on your body by touching a known earth ground. Alternatively, obtain and wear a commercially available discharging wrist strap device, which should be removed for potential shock reasons prior to applying power to the unit under test.
2. After removing an electrical assembly equipped with ES devices, place the assembly on a conductive surface such as aluminum foil, to prevent electrostatic charge buildup or exposure of the assembly.
3. Use only a grounded-tip soldering iron to solder or unsolder ES devices.
4. Use only an anti-static solder removal device. Some solder removal devices not classified as "anti-static" can generate electrical charges sufficient to damage ES devices.
5. Do not use freon-propelled chemicals. These can generate electrical charge sufficient to damage ES devices.
6. Do not remove a replacement ES device from its protective package until immediately before you are ready to install it. (Most replacement ES devices are packaged with leads electrically shorted together by conductive foam, aluminum foil or comparable conductive material).
7. Immediately before removing the protective material from the leads of a replacement ES device, touch the protective material to the chassis or circuit assembly into which the device will be installed.
CAUTION: Be sure no power is applied to the chassis or circuit, and observe all other safety precautions.
8. Minimize bodily motions when handling unpackaged replacement ES devices. (Otherwise harmless motion such as the brushing together of your clothes fabric or the lifting of your foot from a carpeted floor can generate static electricity sufficient to damage an ES device).

CONTROLS AND FUNCTIONS

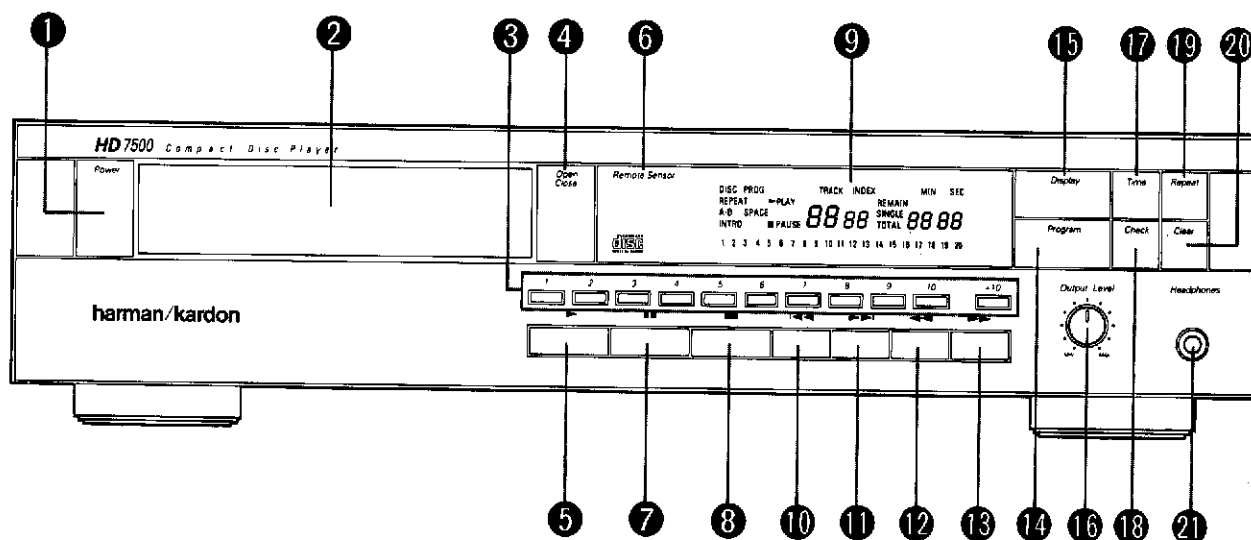
**1 POWER switch**

The POWER switch turns the unit on and off.

2 Compact disc drawer

Load a disc (full-size or 3-inch) into your compact disc player by placing it in this drawer with the label side up. Open and close the drawer using the OPEN/CLOSE button (4).

3 Track selection buttons

This set of buttons (numbered 1 through 10 and +10) enables you to directly select the track you want to play. To select a track with a number higher than 10, press the +10 button, then press the button that will add up to the number of the track you want. For example, to select track 14, press +10, then press 4. If you select a track number that does not exist on your disc, the TRACK indicator will continue to display the number of the last track on the disc. When PROGRAM mode is off, pressing a track button plays the track you select. When PROGRAM mode is on, pressing a track button programs that track into your sequence.

4 OPEN/CLOSE button

Press this button to open or close the compact disc drawer. The drawer will also close if you press the play button or push the drawer gently toward the chassis of the player; however, we recommend that you do not push the drawer.

5 PLAY button

The PLAY button starts playback of a track.

6 REMOTE SENSOR

This area receives the signal from the remote control unit. Make sure this area of the front panel is kept free from dirt or other obstructions that might prevent proper reception of the infrared signal from the remote control.

7 PAUSE button

Pressing the PAUSE button temporarily stops playback. Pressing the PAUSE button again, or pressing PLAY, resumes playback at the precise point where playback left off.

8 STOP button

The STOP button stops playback. When you press PLAY, playback will start either at the beginning of the disc or programmed sequence, or at any track you select.

9 MULTI DISPLAY

Displays the function (DISC, REPEAT, A-B, INTRO, PROGRAM and SPACE), playback mode (PLAY and PAUSE), track number, index number and time.

10 SKIP BACK button

Pressing this button once skips back to the beginning of the present track. If you are in PLAY mode, playback will resume. Holding the button down skips backward to the beginning of each preceding track until the first track on the disc is reached.

11 SKIP FORWARD button

Pressing this button once skips forward to the beginning of the next track. If you are in PLAY mode, playback will resume. Holding the button down skips forward to the beginning of each subsequent track until the last track on the disc is reached.

12 SEARCH BACK button

Holding down this button during playback reverses rapidly through the disc. This function is similar to the "Rewind" function on a tape deck.

13 SEARCH FORWARD button

Holding down this button during playback speeds rapidly forward through the disc. This function is similar to the "Fast forward" function on a tape deck.

14 PROGRAM button

This button puts your compact disc player in and out of PROGRAM mode. Press the button once to turn on PROGRAM mode; press again to turn it off. In PROGRAM mode, you can program a set of tracks to play in any sequence. (For instructions on programming a sequence of tracks, see the Operations section of instruction manual.) When the unit is in PROGRAM mode, the indicator will display the word PROG in red.

15 DISPLAY button

This button turns the display on and off. When you turn the display off in PLAY mode, the entire display goes off. In PAUSE mode, most of the display goes off, but the track number is still displayed. In STOP mode, most of the display goes off, but the total number of tracks on the disc is still displayed. In some systems, turning the fluorescent display off may provide the purest possible sound quality during playback.

16 OUTPUT LEVEL control

This knob controls the volume of the variable output jacks on the rear panel as well as the headphone volume. You can use this output volume control to match the volume of your compact disc player with the volume of your turntable or tuner. In systems where the compact disc player is connected directly to the power amplifier, the OUTPUT LEVEL control provides the volume control for the system.

17 TIME button

During playback or programming, this button cycles through the three TIME display modes

- * The time that has elapsed since the beginning of the current track.
- * The time that remains on the currently selected track.
- * The time that remains on either the entire disc or the programmed sequence.

18 CHECK button

When a disc is loaded but not playing (STOP mode), you can press the CHECK button to see the playback time of each track on the disc. Each time you press the CHECK button, the next track is displayed along with its playback time. When you have stepped sequentially through all the tracks on the disc, another press of the CHECK button displays the total playback time of the entire disc. In PROGRAM mode, the CHECK button displays the cumulative time of the tracks in the programmed sequence. That is, the first press displays the time of the first programmed track, the second press displays the cumulative playback time of the first and second tracks, and so on.

19 REPEAT button

This button puts your compact disc player in and out of REPEAT mode. In REPEAT mode, the unit will continually play back either the entire disc or the programmed sequence of tracks. Press the button once to turn on REPEAT mode; press again to turn off REPEAT mode. When the unit is in REPEAT mode, the indicator will display the word REPEAT.

20 CLEAR button

The CLEAR button removes tracks from your programmed sequence one by one starting with the last track entered. Each time you clear a track from the programmed sequence, that track's time is deleted from the total time displayed. This button is used only in PROGRAM mode.

21 HEADPHONES Jack

Stereo headphones with a standard 1/4" plug can be connected to this jack.

The remote control for the HD7500 provide the same functions found on the front panel of the compact disc player itself. In addition, the remote control provides some functions that are not found on the front panel.

The functions found on the remote control that are not found on the front panel are INTRO, A-B, INDEX, and SPACE. These four functions are described below (for other functions, see the descriptions above).

22 SPACE button

This button puts your compact disc player in and out of SPACE mode. Press the button once to turn on SPACE mode; press again to turn it off. In SPACE mode, the unit inserts 4 seconds of blank space between tracks. This is particularly useful if you are recording music from a compact disc onto a tape. Tape decks with a Music Search feature will be able to use the 4 seconds of space to correctly identify the beginning of each selection on the tape. When the unit is in SPACE mode, the indicator will display the word SPACE.

23 INDEX buttons

Some discs contain long selections that may subdivided into shorter sections (for example, operas). Just as the tracks are marked by the track number, these shorter sections may be marked by index numbers. When you have started playback of the desired track, you can use the INDEX UP and INDEX DOWN buttons to jump to a desired index selection. Each time you press an INDEX button, the INDEX indicator displays the next higher or lower index number. If you continue pressing the button until the indicated index number is higher than the actual number of index selections on the disc, playback will start from the nearest index selection.

24 A-B button

This button puts your compact disc player in and out of A-B mode. In A-B mode, the unit will continually play back a "phrase" or section of your disc beginning at point A and ending at point B. When the unit is in A-B mode, the indicator will display REPEAT A-B.

25 INTRO button

This button puts your compact disc player in and out of INTRO SCAN mode. When INTRO SCAN is on and you press PLAY, the unit plays only the first 15 seconds of each track before moving on to the next. Press the button once to turn on INTRO SCAN mode; press again to turn it off and stop the scanning. When the unit is in INTRO SCAN mode, the indicator will display the word INTRO.

REMOTE CONTROL

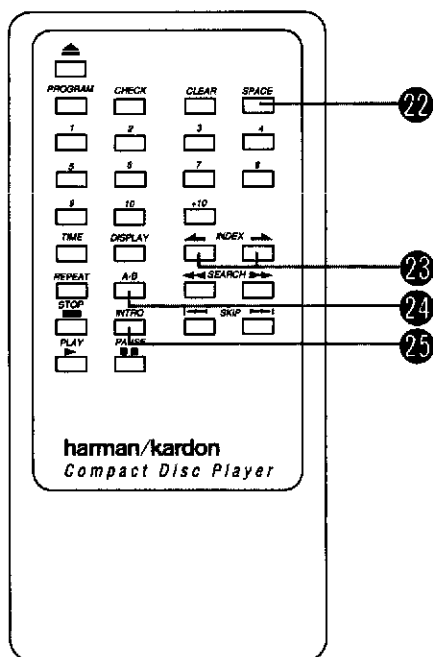

The remote control operates within a 30° angle of the remote sensor on the front panel of the unit. Make sure that the remote's front projection "lens" as well as the REMOTE SENSOR area on the front panel of the unit are kept free from dirt to ensure proper transmission and reception of the infrared beam. Also make sure that no objects (e.g., stereo cabinet doors, end tables) block the path from the remote control to the REMOTE SENSOR area.

Avoid using the remote control near fluorescent lamps, as they may shorten its operating range.

DISASSEMBLY PROCEDURES (REFER TO PAGES 39, 40 AND 44)

[1] CABINET TOP (123) REMOVAL

Remove 7 screws (A) and then remove the Cabinet Top (123).

[2] FRONT PANEL ASS'Y (AA) REMOVAL

1. Remove the Cabinet Top (123), referring to the previous step [1].
2. Disconnect the connector with lead wires (LCN109, LCN110, LCN111, LCN112 and LCN116) from connectors (CN109, CN110, CN111, CN112 and CN116) on the Main P. C. Board (PCB-1).
3. Open the lid of connectors (CN106, CN107 and CN108) on the Main P. C. Board (PCB-1), then disconnect the jumper leads (W106, W107 and W108).
4. Remove 6 screws (B) and then remove the Front Panel Ass'y (AA) with the Front P. C. Board (PCB-2) and the Output Level & Jack P. C. Board (PCB-3).
5. Remove 10 screws (C) and then remove the Front P. C. Board (PCB-2) from the Front Panel Ass'y (AA).
6. Remove a nut (D) fixing the output level volume and then remove the Output Level & Jack P. C. Board (PCB-3) from the Front Panel Ass'y (AA).

[3] MAIN P. C. BOARD (PCB-1) REMOVAL

1. Remove the Cabinet Top (123), referring to the previous step [1].
2. Disconnect the connector with lead wires (LCN115, LCN114, LCN113, LCN117, LCN109, LCN110, LCN111, LCN112 and LCN116) from connectors (CN115, CN114, CN113, CN117, CN109, CN110, CN111, CN112 and CN116) on the Main P. C. Board (PCB-1).
3. Open the lid of connectors (CN119, CN106, CN107 and CN108) on the Main P. C. Board (PCB-1), then disconnect the jumper leads (JL1, JL2, W106, W107 and W108).
4. Remove 9 screws (E) and then remove the Main P. C. Board (PCB-1).

[4] CD PLAYER MECHANICAL ASSEMBLY (103) REMOVAL

1. Remove the Cabinet Top (123), referring to the previous step [1].
2. Disconnect the connector with lead wires (LCN115, LCN114, LCN113 and LCN117) from connectors (CN115, CN114, CN113 and CN117) on the Main P. C. Board (PCB-1).
3. Remove 3 screws (F) and then remove the CD Player Mechanical Assembly (103) backward.

DISASSEMBLING THE CD PLAYER MECHANICAL ASSEMBLY

[5] DISC TRAY (16) REMOVAL

1. Remove the Cabinet Top (123), referring to the previous step [1].
2. Connect the Power cord and turn on the power by pressing the Power switch.
3. Open the Disc Tray (16) by pressing the Open/Close button.
4. With the Disc Tray (16) opened as it is, pull out the power plug.
5. Push the Disc Tray (16) by hand to slide it in once.
6. Loosen the screws (G) and then slide out the Disc Tray (16) by hand.

[6] OPTICAL PICK-UP (52) REMOVAL

1. Remove the CD Player Mechanical Assembly (103), referring to the previous step [4].
2. Remove 4 screws (H) and then remove the Disc Motor Ass'y (63) with Pick-up, Slide Motor and etc.
3. Remove 2 screws (I) and then remove the Gears (59 and 60).
4. Remove the 2 screws (J) and then remove the Shaft Clamps (62), then remove the Pick-up (52) with shaft.

[7] SLIDE MOTOR (57) REMOVAL

1. Remove the Gears (59 and 60), referring to the previous step [6]-3.
2. Unsolder the terminal of Disc and Slide Motors, then remove the Motor P. C. Board (65).
3. Remove 2 screws (K) and then remove the Slide Motor (57).

POWER CORD REPLACEMENT (FOR SERVICE ENGINEERS OTHER THAN NORTH AMERICA)

In order to prevent fire or shock hazard when replacing the power cord, follow the procedure below to replace the part with the standard supply parts.

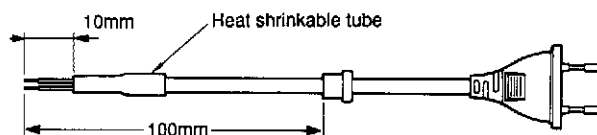
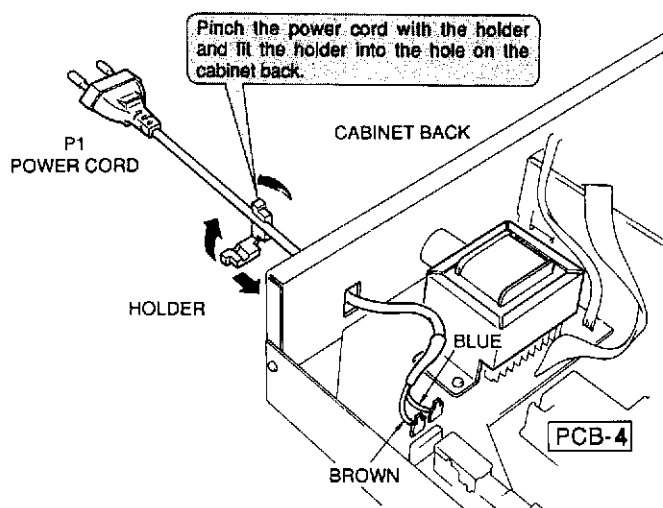

ADJUSTMENT PROCEDURE

1. Instruments required

- DC voltmeter
- Oscilloscope (3 or more modes, 100 MHz, input select DC range)
- Jitter meter
- Test disc: EIAJ CD-1

2. Adjustment points

2-1 Adjusting screw layout for CD player mechanical assembly.

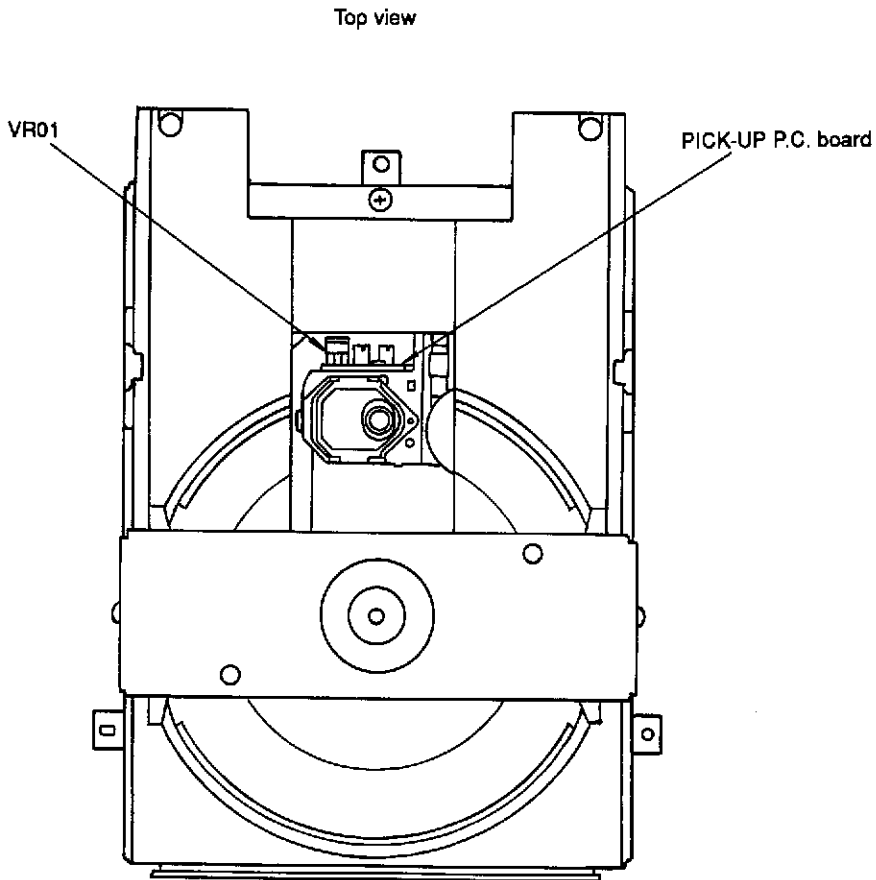

2-2 VR and test point layout for main P.C. board.

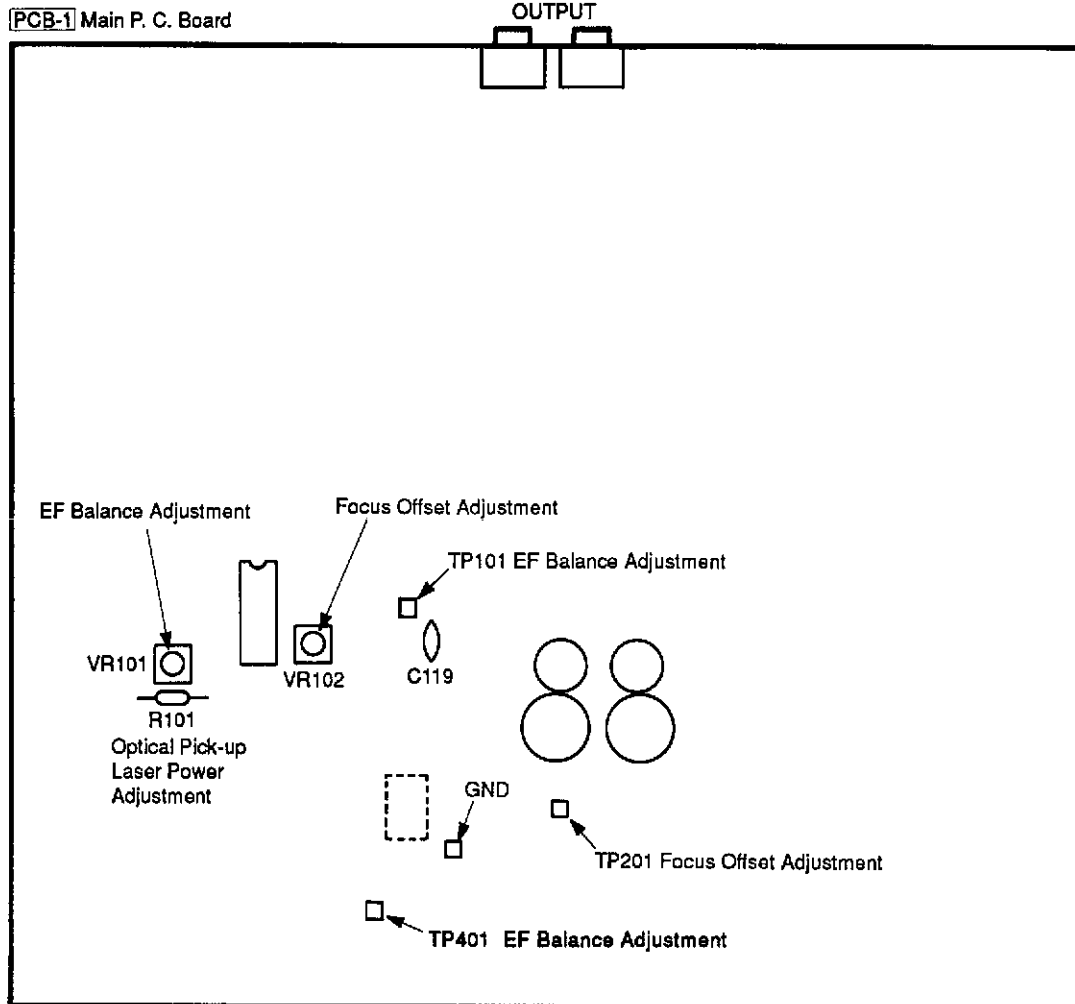

3. Optical Pick-up Laser Power Adjustment

The specified value for adjustment varies with the type of the pick-up in use. Obtain the voltage value according to the following procedure.

- (a) Read the current value on the label of the pick-up P.C.board.
- (b) Using the amperage of the current and the following equation, calculate the voltage value.

When the current is 64.5mA:
 $V=0.0645A \times 22=1.419V$

- (1) Connect the DC voltmeter to both ends of R101.
- (2) Insert EIAJ CD-1 test disc and place the unit in the Play mode.
- (3) Adjust VR01 in the pick-up P.C.board to the voltage obtained in step (b) above.

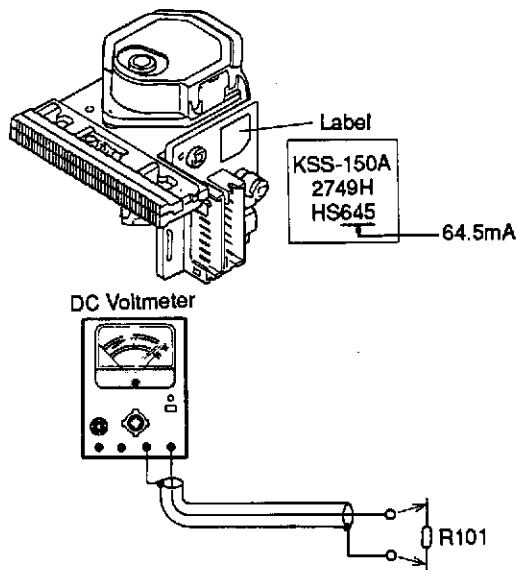

4. EF Balance Adjustment

- (1) Connect the oscilloscope (0.5V/div, 5 msec./div, DC mode) to TP101 and GND.
Short-circuit TP401 and GND.
- (2) Insert EIAJ CD-1 test disc and place the unit in the Play mode.
- (3) Adjust VR101 so that the amplitude above and below the zero DC line becomes equal. (Amplitude A = Amplitude B)

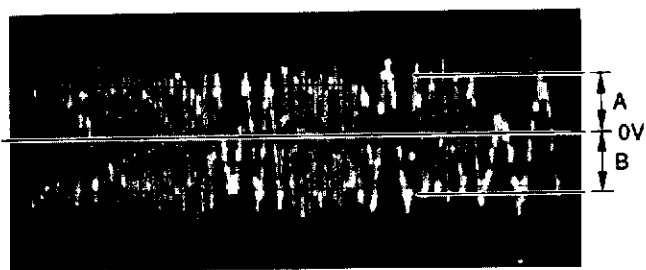
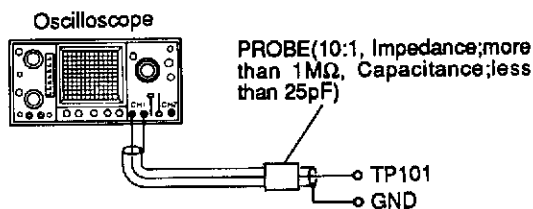

A=B

(approx. 1.5Vp-p)

5. Focus Offset Adjustment

- (1) Connect the Jitter meter to TP201 and GND.
- (2) Insert EIAJ CD-1 test disc and place the unit in the play mode.
- (3) Adjust VR102 until the jitter for optimum sensitivity.

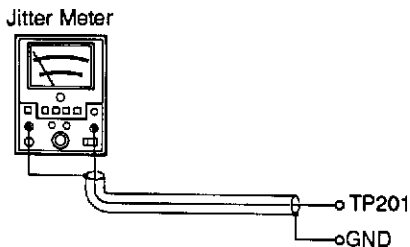

6. Jitter Inclination Confirmation

- (1) Connect the Jitter meter (sigma range) to TP201 and GND.
- (2) Insert EIAJ CD-1 test disc and place the unit in the Play mode.
- (3) Confirm the jitter meter reading is less than 30ns.

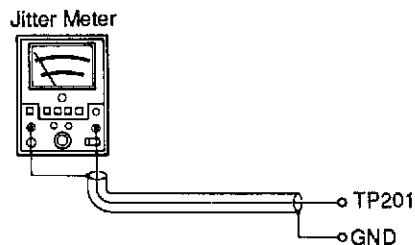

TROUBLE SHOOTING

When a trouble has occurred, first check the pick-up lens for dirt and each connector for tight and secure connection. If the problem persists after checking both of these items, use the following check procedures.

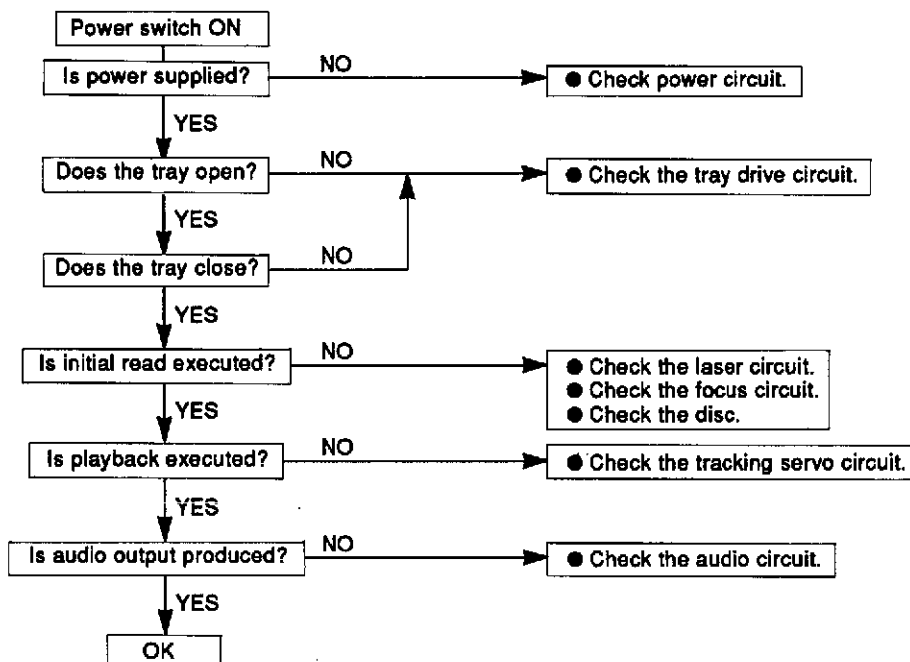

(1) When Multi Display fails to light properly

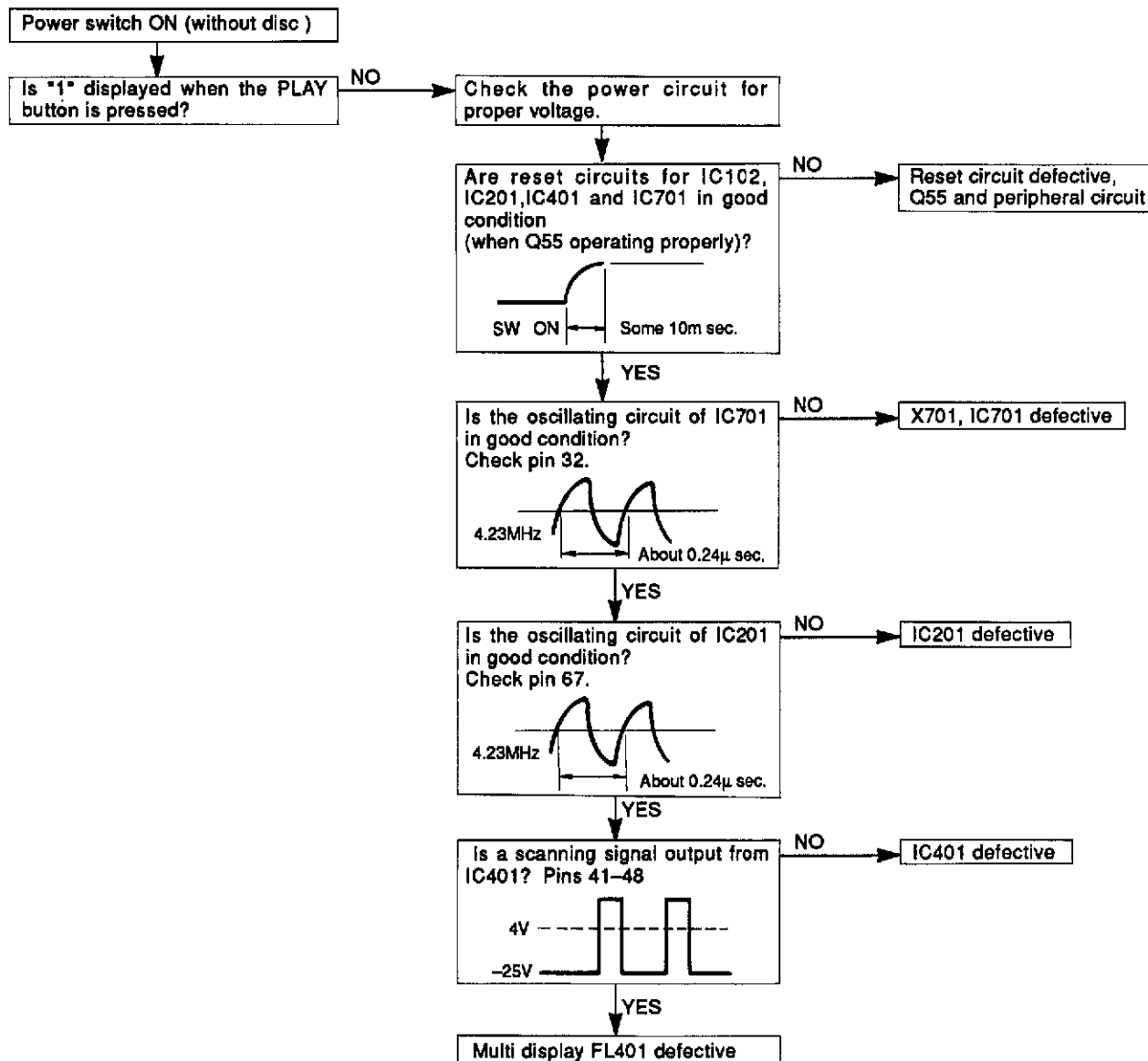

A When laser beam is not emitted

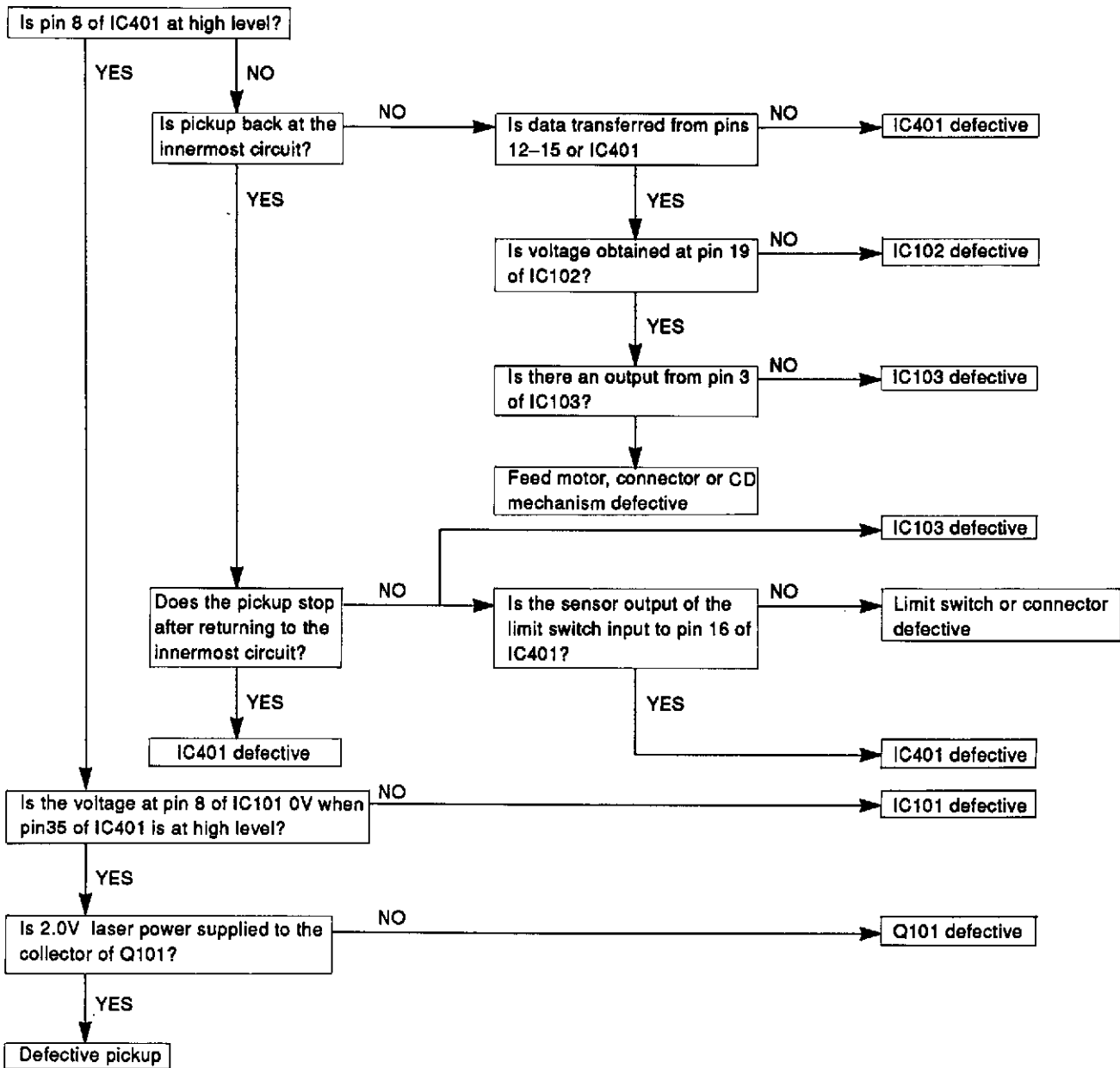

B When laser beam is emitted

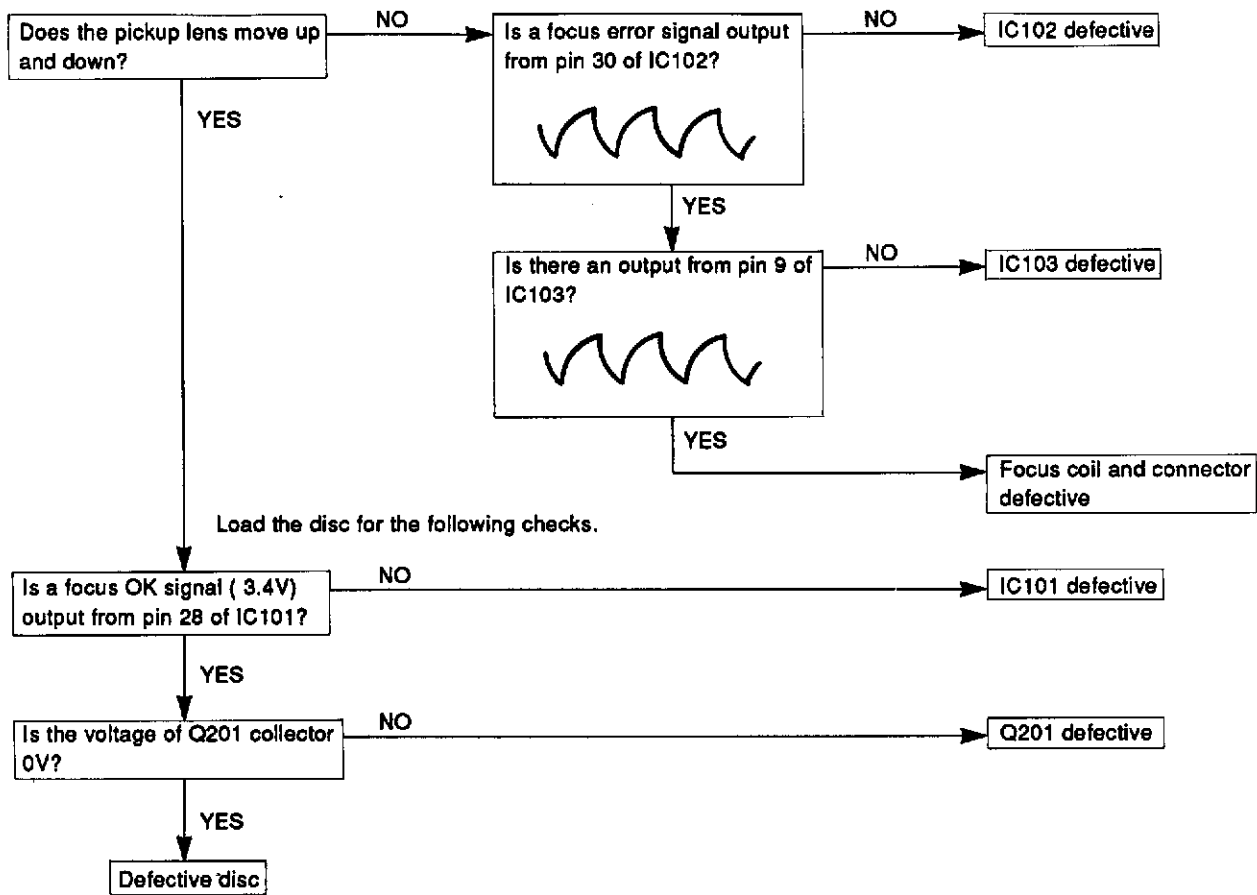

When there is no audio output

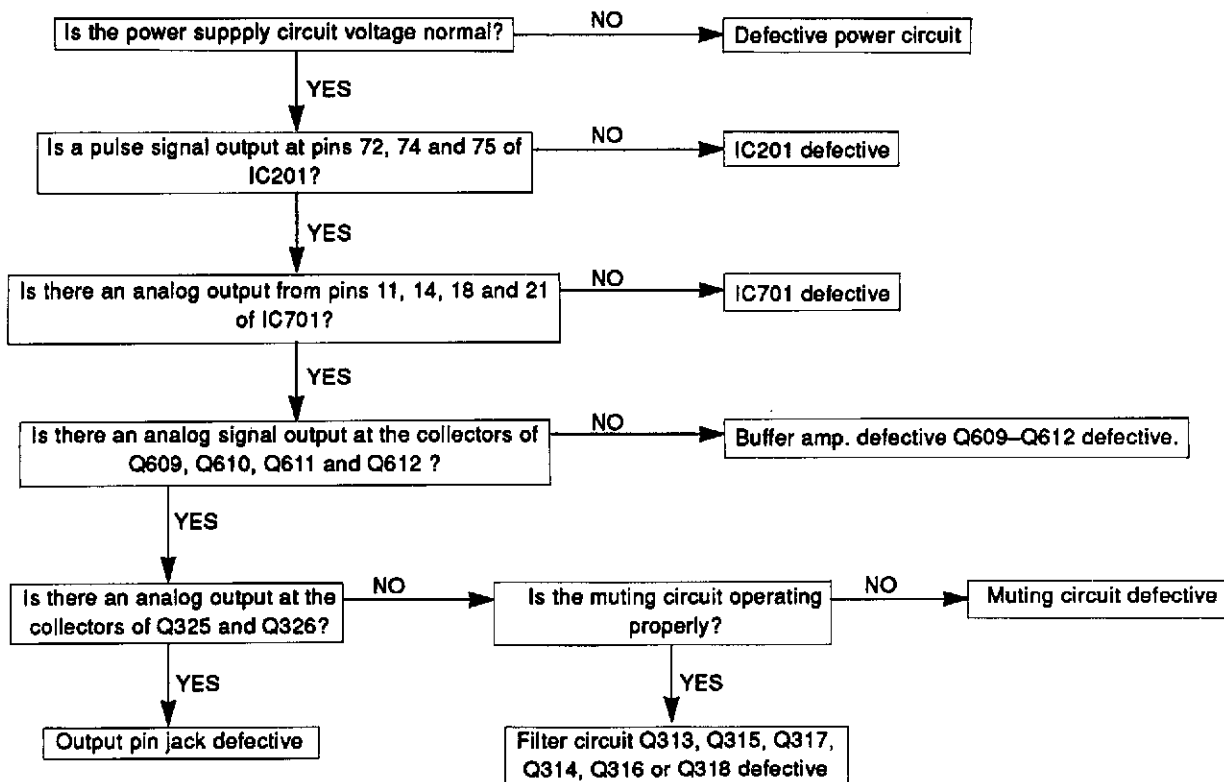

(2) When the tray fails to operate properly

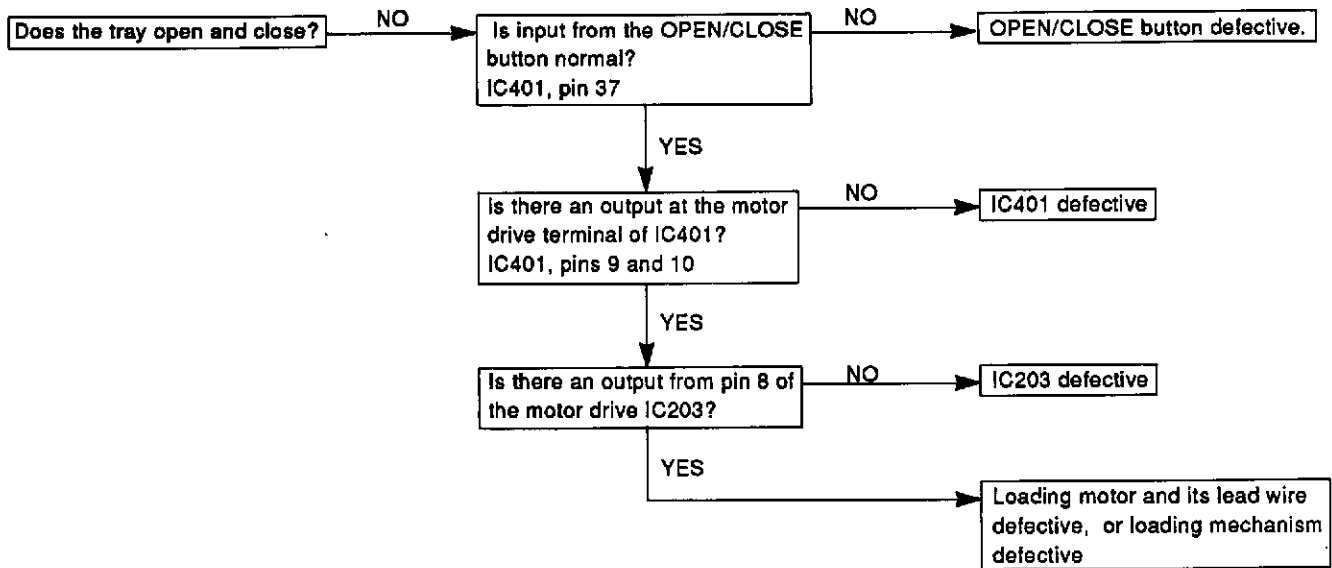

(3) When Initial read cannot be executed

The following checks can be done without a disc loaded.

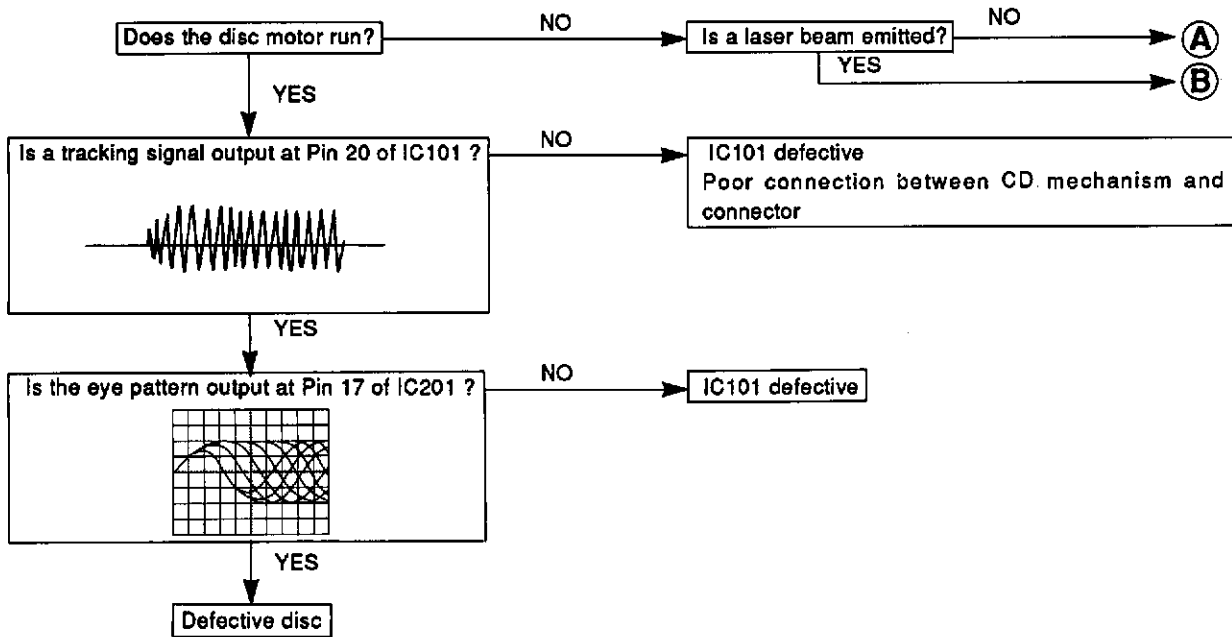

IC TERMINAL FUNCTIONS

IC number	Terminal number	Port name	Terminal code	I/O	Outline of functions
IC101	1	RFI		I	RF summing amp. input terminal.
	2	RFO		O	RF summing amp. output terminal.
	3	RF-		I	RF summing amp. return input terminal.
	4	P/N		I	Laser diode P/N select terminal.
	5	LD		O	APC LD amp. output terminal.
	6	PD		I	APC PD amp. input terminal.
	7	PD1		I	RF I-V amp. (1) invert input terminal.
	8	PD2		I	RF I-V amp. (2) invert input terminal.
	9	VC		—	GND terminal.
	10	F		I	F I-V amp. invert input terminal.
	11	E		I	E I-V amp. invert input terminal.
	12	EO		O	E I-V amp. output terminal.
	13	EI		I	E I-V amp. return input terminal.
	14	VR		O	DC voltage output terminal.
	15	CC2		I	DEFECT signal input terminal.
	16	CC1		O	DEFECT signal output terminal.
	17	VEE		—	Negative power terminal.
	18	FE BIAS		I	Focus error amp. bias terminal.
	19	FE		O	Focus error amp. output terminal.
	20	TE		O	Tracking error amp. output terminal.
	21	DEFECT		O	DEFECT comparator output terminal.
	22	MIRR		O	MIRR comparator output terminal.
	23	CP		I	MIRR hold capacitor connect terminal.
	24	CB		I	DEFECT hold capacitor connect terminal.
	25	DGND		—	GND terminal.
	26	ASY		I	Auto asymmetry control input terminal.
	27	EFM		O	EFM comparator output terminal.
	28	FOK		O	Focus OK comparator output terminal.
	29	$\overline{\text{LD ON}}$		I	Laser diode on/off select terminal.
	30	Vcc		—	Positive power terminal.

IC number	Terminal number	Port name	Terminal code	I/O	Outline of functions
IC102	1	TE IN	Pre amp. input	I	Tracking error signal input terminal.
	2	TC IN	Pre amp. input	I	Track cross signal input terminal.
	3	SHOCK IN	Pre amp. input	I	Shock detector signal input terminal.
	4	HF OK	Pre amp. input	I	HF OK signal input terminal.
	5	MR	Pre amp. input	I	Mirror detected signal input terminal.
	6	Jump Flag	Mi-com I/O	O	Outputs "H" under jump function.
	7	$\overline{\text{HFD}}$	Mi-com I/O	O	"1" indicates that MR input is "1" and track servo loop is off (TS OFF, JF, JR).
	8	T-HLD	Track servo	I	Direct control terminal for TS1 switch. "1" indicates that TS1 switch is "b". "0" indicates that priority is given to controller command.
	9	DATA OUT	Mi-com I/O	O	Inner condition output changed by command modes.
	10	$\overline{\text{JP1}}$	Mi-com I/O	I	1 track jump control signal. Usually "H".
	11	MSD	Mi-com I/O	I	Serial data input terminal (LSB first, 8-bit data).
	12	$\overline{\text{MLA}}$	Mi-com I/O	I	Latch signal of serial data from mi-com to servo IC.
	13	MCK	Mi-com I/O	I	Clock signal of serial data from mi-com to servo IC. Receives data on leading edge.
	14	$\overline{\text{ACLR}}$	Mi-com I/O	I	All clear input. (Clear inner registers and flip-flops by "L" signal.)
	15	Bias	Power supply	O	Vcc/2 bias power supply output when single-pole power supply is used.
	16	COM	Power supply	I	Common terminal. Connect to GND when double-pole power supply is used and to BIAS when single-pole power supply is used.
	17	GND	Power supply	I	GND terminal.
	18	VEE	Power supply	I	Negative power terminal. Connect to GND when single-pole power supply is used.
	19	SS OUT	Slide servo	O	Operation amplifier SS output.
	20	SS ⊖	Slide servo	I	Operation amplifier SS reverse input.
	21	SS ⊕	Slide servo	I	Operation amplifier SS non-reverse input.
	22	TS OUT	Track servo	O	Operation amplifier TA output.

IC number	Terminal number	POF name	Terminal code	I/O	Outline of functions
IC102	23	TS \ominus	Track servo	I	Operation amplifier TA reverse input.
	24	TG2	Track servo	—	Track gain select switch TG2 output. Set to open or common level.
	25	TS \oplus	Track servo	I	Operation amplifier TA non-reverse input.
	26	TG1	Track servo	—	Track gain select switch TG1 output. Set to open or common level.
	27	TE OUT	Track servo	O	Operation amplifier TE output.
	28	TE \ominus	Track servo	I	Operation amplifier TE reverse input.
	29	FSR IN	Focus servo	I	Focus search voltage level detector input.
	30	FS OUT	Focus servo	O	Operation amplifier FA output.
	31	FS \ominus	Focus servo	I	Operation amplifier FA reverse input.
	32	FS \oplus	Focus servo	I	Operation amplifier FA non-reverse input.
	33	FG	Focus servo	—	Focus gain select switch FG output. Set to open or common level.
	34	C-FSR	Focus servo	—	Connect capacitor which determines time constant of focus search waveform.
	35	I-Ref	Power supply	I	Terminal for connecting resistor for setting current value of reference current source.
36	Vcc	Power supply	I	Positive power terminal.	
IC103	1	+VIN 1		I	Positive input terminal 1 for amp. 1.
	2	-VIN 1		I	Negative input terminal 1 for amp. 1.
	3	OUT 1		O	Output terminal 1.
	4	OUT 2		O	Output terminal 2.
	5	-VIN 2		I	Negative input terminal 2 for amp. 2.
	6	+VIN 2		I	Positive input terminal 2 for amp. 2.
	7	+VIN 3		I	Positive input terminal 3 for amp. 3.
	8	-VIN 3		I	Negative input terminal 3 for amp. 3.
	9	OUT 3		O	Output terminal 3.
	10	NC		—	

IC number	Terminal number	Terminal name	Terminal type	I/O	Outline of functions
IC103	11	NC		—	
	12	Vcc		—	Positive power supply.
IC201	1	EMP		O	Emphasis code output. Emphasis = "1"
	2	PWM1		O	Disc motor drive PWM output 1. -
	3	PWM2		O	Disc motor drive PWM output 2. +
	4	DOTX		O	Digital output.
	5	ACRCY		I	Channel status clock input.
	6	TEST1		I	Test mode select input.
	7	DOBSEL		I	Output data bit select.
	8	DASEL1		I	D/A converter interface select input 1.
	9	DASEL2		I	D/A converter interface select input 2.
	10	DASEL3		I	D/A converter interface select input 3.
	11	DASEL4		I	D/A converter interface select input 4.
	12	MSD		I	Microcomputer interface serial data input.
	13	MCK		I	Microcomputer interface shift clock input.
	14	\overline{MLA}		I	Microcomputer interface data latch clock input
	15	\overline{ACLR}		I	Microcomputer interface register clear input.
	16	\overline{HFD}		I	Play signal absence signal input.
	17	HF		I	Play signal input.
	18	IREF		I	Detection/PLL circuit reference current input.
	19	TLC		O	Slice level control output.
	20	LPF		I/O	PLL loop filter connection terminal.
	21	LOCK/DRD		O	Synchronous/low disc rotate status output.
	22	SYCLK		O	Frame synchronous status output.
	23	Vdd2		I	5V power supply used for Detection/PLL circuit analog area only.
	24	DRD		O	Low disc rotate status output.
	25	EFFK		O	EFM frame clock output.
	26	SCINT		O	Subcode Q interrupted signal output.
	27	SQRO		O	Subcode Q register output.
	28	SQRCK		I	Subcode Q register data shift clock input.
	29	SCOR		O	Subcode synchronous signal output.

IC number	Terminal number	Port name	Terminal code	I/O	Outline of functions
IC201	30	CRCF		O	Subcode Q CRC check result output.
	31	SCCK		I	Shift clock input for serial subcode data output.
	32	Vss2		I	GND terminal.
	33	SCOE2		I	Subcode parallel output channel P to S enable input.
	34	SCOE1		I	Subcode parallel output channel T to W enable input.
	35	SBCW		O	Subcode channel W output.
	36	SBCV		O	Subcode channel V output.
	37	SBCU		O	Subcode channel U output.
	38	SBCT		O	Subcode channel T output.
	39	SBCS		O	Subcode channel S output.
	40	SBCR		O	Subcode channel R output.
	41	SBCQ		O	Subcode channel Q output.
	42	SBCP		O	Subcode channel P output.
	43	$\overline{\text{RAS}}$		O	Row address strobe signal output.
	44	NC		—	
	45	RDB2		I/O	External memory data I/O 2.
	46	NC		—	
	47	RDB1		I/O	External memory data I/O 1.
	48	RDB4		I/O	External memory data I/O 4.
	49	$\overline{\text{CAS}}$		O	Column address strobe signal output.
	50	RDB3		I/O	External memory data I/O 3.
	51	WE		O	Write enable signal output.
	52	NC		—	
	53	RAD1		O	External memory address output 1.
	54	RAD2		O	External memory address output 2.
	55	RAD3		O	External memory address output 3.
	56	RAD7		O	External memory address output 7.
	57	RAD4		O	External memory address output 4.
	58	RAD5		O	External memory address output 5.
59	RAD6		O	External memory address output 6.	

IC number	Terminal number	Port name	Terminal Code	I/O	Outline of functions
IC201	60	RAD0		O	External memory address output 0.
	61	EST2		O	Error status 2.
	62	EST1		O	Error status 1.
	63	VDD1		I	5V power supply.
	64	DOFK		O	OSC frame clock output.
	65	FSCK		O	Clock output. 44.1kHz
	66	C846		O	Clock output. 8.4672MHz
	67	C423		O	Clock output. 4.2336MHz
	68	C16MI		I	1/2 divider input.
	69	C8MO		O	1/2 divider output.
	70	XI		I	Crystal oscillator input.
	71	XO		O	Crystal oscillator output.
	72	DO1		O	D/A converter serial data output.
	73	VSS1		I	GND terminal.
	74	DSCK		O	D/A converter data shift clock output.
	75	LRCK		O	D/A converter left/right clock output.
	76	DO2		O	Dual D/A converter serial data output.
	77	WDCK		O	D/A converter word clock.
	78	DLRCK		O	D/A converter left/right clock output.
	79	APTL		O	D/A converter deglitch clock L.
80	APTR		O	D/A converter deglitch clock R.	
IC202	1	\overline{OE}		I	Output enable input.
	2	DQ1		I/O	Data I/O.
	3	DQ2		I/O	Data I/O.
	4	\overline{W}		I	Write control input.
	5	\overline{RAS}		I	Row address strobe input.
	6	A6		I	Address input.
	7	A5		I	Address input.
	8	A4		I	Address input.
	9	VCC		—	Power supply (5V).
	10	A7		I	Address input (row address only).

IC number	Terminal number	Port name	Terminal code	I/O	Outline of functions
IC202	11	A3		I	Address input.
	12	A2		I	Address input.
	13	A1		I	Address input.
	14	A0		I	Address input (row address only)
	15	DQ3		I/O	Data I/O.
	16	$\overline{\text{CAS}}$		I	Column address strobe input.
	17	DQ4		I/O	Data I/O.
	18	Vss		—	Power supply (0V).
IC203	1	VSENCE1			
	2	OUT1		O	Output terminal 1.
	3	-VIN1		I	Negative power supply.
	4	+VIN1		I	Positive input 2.
	5	VEE			Negative input 2.
	6	+VIN2		I	Positive power supply.
	7	-VIN2		I	Negative input 2.
	8	OUT2		O	Output terminal 2.
	9	VSENCE2			
	10	Vcc			Positive power supply.
IC401	1	Vcc			Positive power supply.
	2	P65		I/O	
	3	P64		I/O	
	4	P63		I/O	
	5	P62		I/O	
	6	P61		I/O	
	7	P60		I/O	
	8	P27	I/O port	I/O	Disc tray open direction driving output.
	9	P28	I/O port	I/O	Disc tray close direction driving output.
	10	P25	I/O port	I/O	
	11	P24	I/O port	I/O	Serial data output.
	12	P23	I/O port	I/O	Serial data output.
	13	P22	I/O port	I/O	Data latch clock output.

IC number	Terminal number	Port name	Terminal code	I/O	Outline of functions
IC401	14	P21	I/O port	I/O	
	15	P20	I/O port	I/O	
	16	P37	OUT PORT	O	Display output i.
	17	P36	OUT PORT	O	Display output g.
	18	P35	OUT PORT	O	Display output f.
	19	P34	OUT PORT	O	Display output e.
	20	P33	OUT PORT	O	Display output d.
	21	P32	OUT PORT	O	Display output c.
	22	P31	OUT PORT	O	Display output b.
	23	P30	OUT PORT	O	Display output a.
	24	P53			
	25	P52			
	26	CNVss			Usually connected to Vss.
	27	$\overline{\text{RESET}}$		I	Reset input.
	28	XIN	CLOCK IN	I	Clock input.
	29	XOUT	CLOCK OUT	O	Clock output.
	30	XCIN	CLOCK IN	I	Serial data input.
	31	XCOU	CLOCK OUT	O	Clock output.
	32	Vss			Power Supply.
	33	Ø		O	Timing output.
	34	P57			
	35	P56			
	36	P55			
	37	P54			
	38	VP		I	Pull down voltage input.
	39	P51			
	40	P50			
	41	P17	OUT PORT	O	Laser diode control output.
	42	P16	OUT PORT	O	Display output 7.
	43	P15	OUT PORT	O	Display output 6.
	44	P14	OUT PORT	O	Display output 5.

IC number	Terminal number	Port name	Terminal code	I/O	Outline of functions
IC401	45	P13	OUT PORT	O	Display output 4.
	46	P12	OUT PORT	O	Display output 3.
	47	P11	OUT PORT	O	Display output 2.
	48	P10	OUT PORT	O	Display output 1.
	49	P07	I/O port	I/O	Serial data input.
	50	P06	I/O port	I/O	Frame synchronous state output.
	51	P05	I/O port	I/O	Low disc rotate state output.
	52	P04	I/O port	I/O	Sub-code synchronous signal output.
	53	P03	I/O port	I/O	Sub-code Q check.
	54	P02	I/O port	I/O	Sub-code channel Q output.
	55	P01	I/O port	I/O	Interrupt input.
	56	P00	I/O port	I/O	
	57	P47			
	58	P46			
	59	P45			
	60	P44			
	61	P43			
62	P42				
63	P41				
64	P40				
IC501	1	OUT1		O	Output terminal 1.
	2	In1		I	Negative input terminal 1 for amp. 1.
	3	IN1		I	Positive input terminal 1 for amp. 1.
	4	V-			Negative power supply.
	5	In2		I	Positive input terminal 2 for amp. 2.
	6	Ii2		I	Negative input terminal 2 for amp. 2.
	7	OUT2		O	Output terminal 2.
	8	V+			Positive power supply.
IC701	1	MLD		I	Mi-com command load input terminal. Low level=load
	2	RSTB			Reset terminal. Low level=active
	3	IE		I	Low level=LSI format. High level=I2S format.

Pin DNL	Terminal Number	Foot Name	Terminal Code	I/O	Outline of functions
IC701	4	TP1		O	Digital filter test output terminal 1.
	5	TP2		O	Digital filter test output terminal 2.
	6	TEST 1		I	Digital filter test signal input terminal 1. Nominal=Low level
	7	TEST 2		I	Digital filter test signal input terminal 2. Nominal=Low level
	8	NC			
	9	NC			
	10	AVDD 4			Analog power supply terminal 4. (+5V)
	11	OUTL(-)		O	L ch. negative PWM output terminal.
	12	AVSS 4			Analog ground terminal 4.
	13	AVSS 3			Analog ground terminal 3.
	14	OUTL(+)		O	L ch. positive PWM output terminal.
	15	AVDD 3			Analog power supply terminal 3. (+5V)
	16	NC			
	17	AVDD 2			Analog power supply terminal 2. (+5V)
	18	OUTR(+)		O	R ch. positive PWM output terminal.
	19	AVSS 2			Analog ground terminal 2.
	20	AVSS 1			Analog ground terminal 1.
	21	OUTR(-)		O	R ch. negative PWM output terminal.
	22	AVDD 1			Analog power supply terminal 1. (+5V)
	23	DVDD 1			Digital power supply terminal 1 for oscillator. (+5V)
	24	DVSS 1			Digital ground terminal 1 for oscillator.
	25	X2			Crystal oscillator.
	26	X1			Crystal oscillator (external clock input terminal).
	27	NC			
	28	DVDD 2			Digital power supply terminal 2. (+5V)
	29	DVSS 2			Digital ground terminal 2.
	30	NSUB			Connect to the D-VDD terminal.
	31	ZFLGB		O	Zero signal detect output terminal.
	32	192FS		O	Clock output. 8.4672MHz
	33	LRPOL			Polarity (L ch. and R ch.) select terminal. L level=R H level=L
	34	LRCLK		I	LRCLK input terminal.
	35	BCLK		I	Serial input bit clock.

IC number	Terminal number	Port name	Terminal code	I/O	Outline of functions
IC701	36	SRDATA		I	Serial data input terminal.
	37	DVSS 3			Digital ground terminal 3.
	38	DVDD			Digital power supply terminal. (+5V)
	39	384FS		O	Clock output. 16.9344MHz
	40	PD			Power down terminal. High level=active
	41	MDATA		I	Mi-com command data input terminal.
	42	MCLK		I	Clock input terminal for mi-com command.

CIRCUIT DESCRIPTION

1. APC CIRCUIT

A semiconductor laser is used as the light source for the optical pickup. As the output from the semiconductor laser changes radically with changes in temperature, a circuit must be provided to stabilize this output. For this purpose, a monitor diode which detects the optical output of the laser diode is used in the semiconductor laser.

As the laser diode emits light from its bonded surface, light is emitted both in front and behind. The light emitted behind is monitored with the monitor diode installed on its rear surface, and the optical output is thus controlled. The light emitted in front becomes the light source for the pickup.

Fig. 1 shows the APC circuit.

When the temperature rises and the optical output decreases, the monitor diode current (I_S) decreases, the electric potential of IC101 pin 5 rises, the base current of the driving transistor increases, and the laser diode current increases. This causes the reduced optical output to return to its former level.

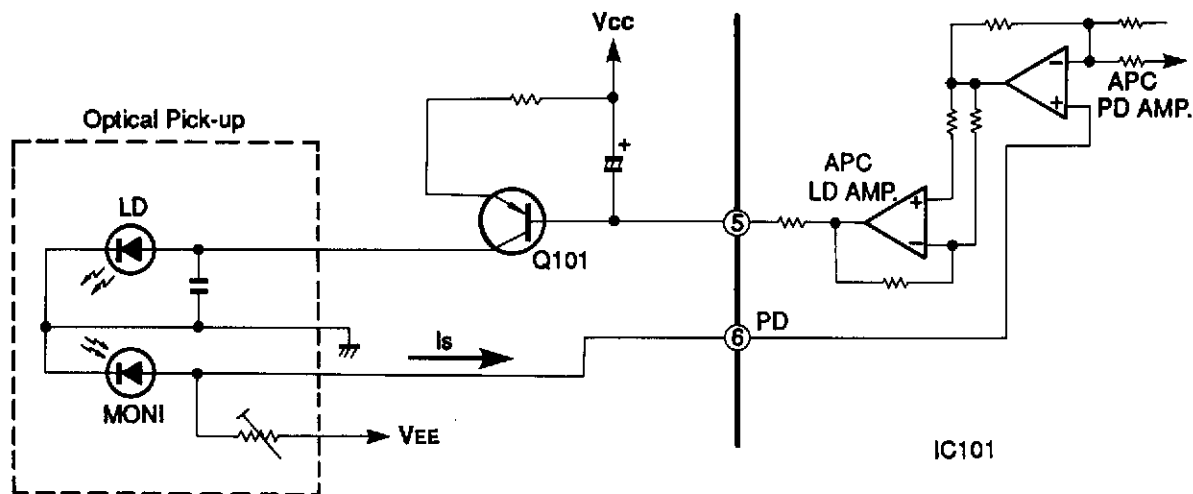

Fig. 1

2. FOCUS SERVO

2-1. Optical pickup

This set employs a three-beam optical pickup comprised of six division photodiodes, A through F as shown in Fig. 2. The four photodiodes (A through D) at the center provide focus error detection by using their property to allow the beam to focus into a round image only at a certain point.

The sums of outputs from diagonal two elements of four division photodiodes (A+C and B+D) are compared by the differential amplifier in IC101 to detect the shape of the beam image.

The remaining two diodes (E and F) provide tracking error detection by means of sub-beam spots.

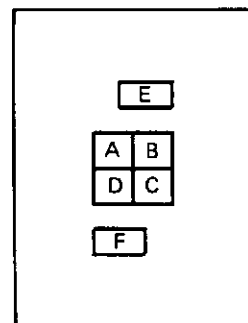

Three spotted (six-division) photo diodes

Fig. 2

2-2. Focus error detecting operation

The reflected laser beam from a disc is polarized 90° with the beam-splitter and sent to the cylindrical lens. The beam passed through this cylindrical lens is then sent to the four division photodiodes and focuses into an image whose shape varies with the distance between the disc and the objective lens. Such change in the beam shape causes the current flowing from the photodiodes to vary.

Shown in Fig. 3 is the principle of the focus error detection.

The currents from the photodiodes (A+C and B+D) are applied to pins 7 and 8 of IC101 and converted to voltage by RF I-V amplifiers (1) and (2) included in IC101.

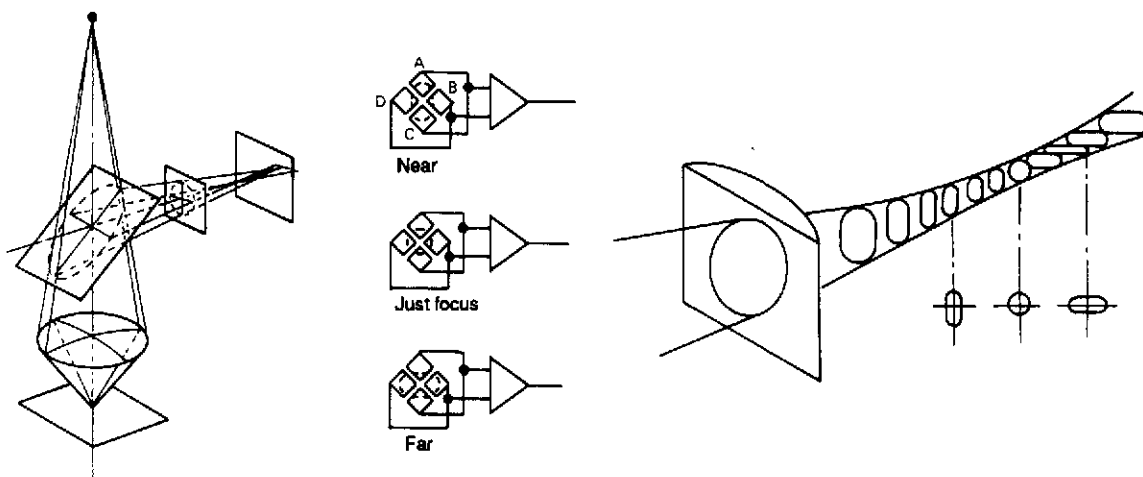

Fig.3

2-3. Focus servo control operation

The focus error signal, after begin converted to voltage by the RF I-V amplifier, is transmitted to the operation amplifier in the IC and output from pin 19.

When the disc to objective lens distance is in just focus, the beam forms a true round. In this state, the beams applied to four elements of four division photodiodes become equal and thus the output provided then is 0(zero). When the disc to objective lens distance is too close (near focus), the beam is reflected divergently to form an oval in crosswise direction. In this state, the outputs provided from photodiodes A and C are higher than those from B and D, resulting in negative (-) output voltage. On the other hand, when the distance is too far (far focus), the beam is reflected convergently to form an oval in longitudinal direction. Then the outputs from photodiodes B and D are higher, resulting in positive (+) output.

The output voltage(focus error signal) from pin 19 of IC101 passes through IC102 , in from pin 32 and out from pin 30, and IC103, in from pin 7 out from pin 9 as shown in Fig. 4. It is amplified in each IC and fed to the focus coil which then drives the objective lens of the pickup.

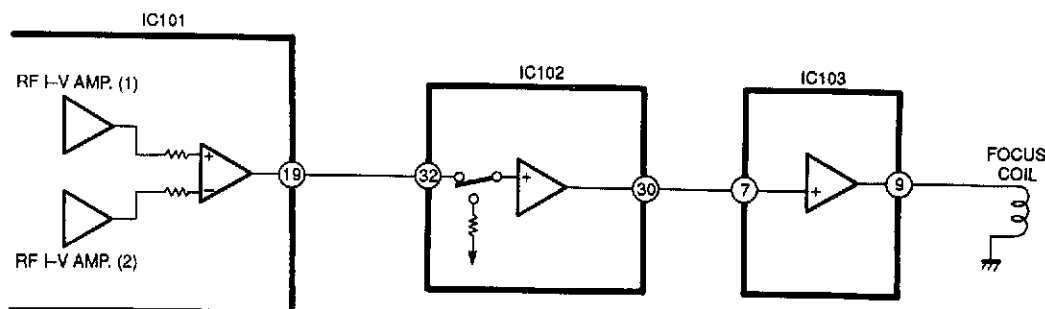

Fig. 4

2-4. Tracking error detection system

Fig. 5 shows the principle of the tracking error detection system which employs the three beam system.

The laser beam is divided into the main beam and two sub-beams by diffraction grating and they are arranged on one line. The center line connecting these three beams has a slight offset angle against the main beam. The main beam is received by photodiodes A, B, C and D and two sub-beams by E and F respectively.

Fig. 5-A shows the on-track state. As both auxiliary beams 1 and 2 are slightly on the track in this state, the outputs of photodiodes E and F are equal and the tracking signal is 0(zero). When the track is shifted to the left (Fig. 5-B), the auxiliary beam 1 is off the pit. This allows more light to be received by the photodiode E, resulting in positive (+) tracking signal output. On the other hand, when the track is shifted to the right (Fig. 5-C), the amount of light received by the photodiode F increases, resulting in negative (-) tracking signal output. And these extreme signals are detected as tracking error signals.

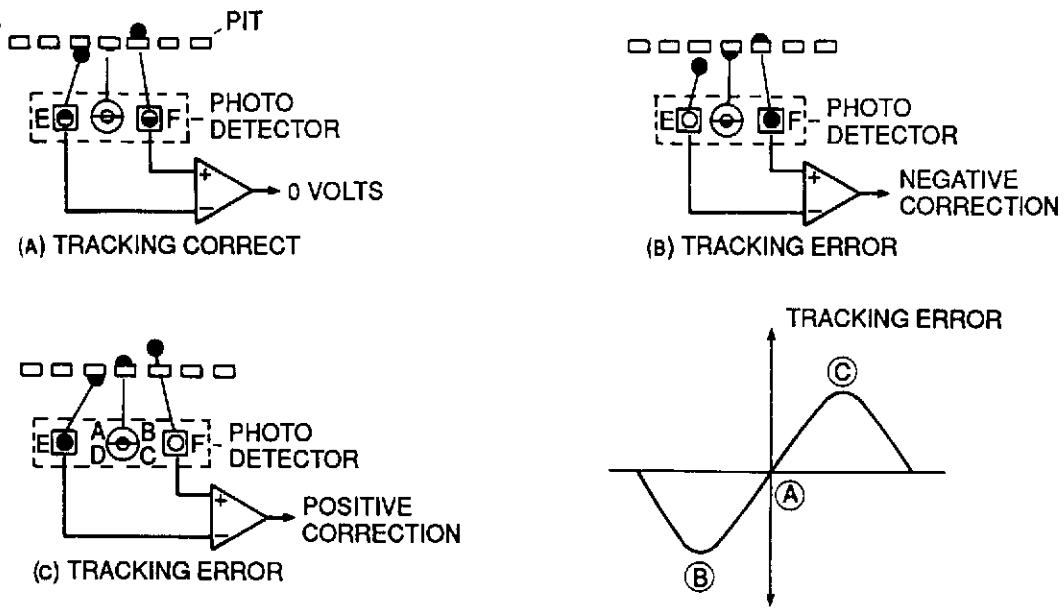

Fig. 5

2-5. Tracking servo control operation

When a tracking error signal is detected by photodiodes E and F, it is fed to pins 11 and 10 of IC101 respectively as shown in Fig. 6. In IC101, the signal is converted into voltage by the E I-V amplifier and F I-V amplifier, transmitted to the tracking error amplifier and output through pin 20. While it passes through IC102, in from pin 1 and out from pin 22, and IC103, in from pin 6 and out from 4, it is amplified in each IC and sent to the tracking coil to adjust pickup so that the amount of track shift is reduced as closely to none as possible.

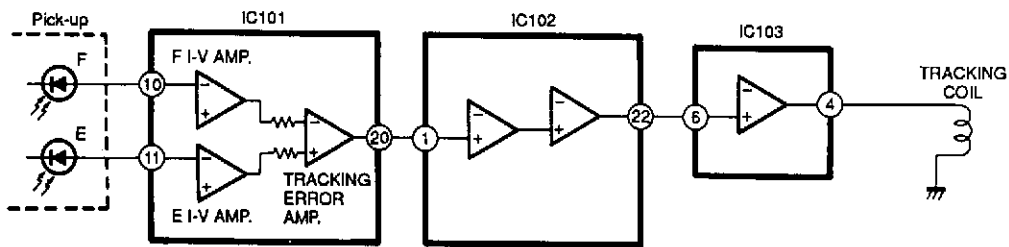

Fig. 6

3. Regenerative Circuit

3-1. RF circuit

The currents from photodiodes (a, b, c and d) are fed to IC101 through pins 7 and 8 and converted to voltage by RF I-V amplifiers (1) and (2) respectively there, added by the RF summing amplifier and output from pin 2 as a signal. As it is sent to pin 7 of IC201, it can be checked at the test point (TP201) provided on its way by means of the eye pattern check.

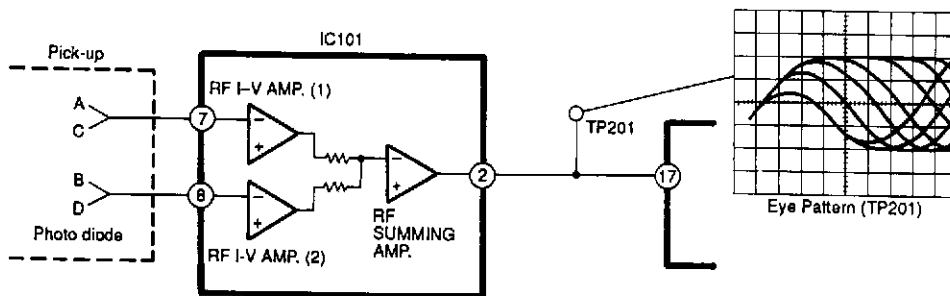

Fig. 7

3-2. EFM demodulation, error correction, serial/parallel conversion

EFM demodulation, error correction and serial/parallel conversion are performed by the internal circuitry of IC201. The eye-pattern signals from pin 2 of IC101 are sent to pin 17 of IC201, then demodulated from 14 bits to 8 bits by EFM readjustment. At the same time any error, if found, is corrected (CIRC) and the signals are sent to the D/A converter interface. After that, they are output as 18-bit digital signals from pins 72, 74 and 75 of IC201 and fed to the D/A converter of IC701.

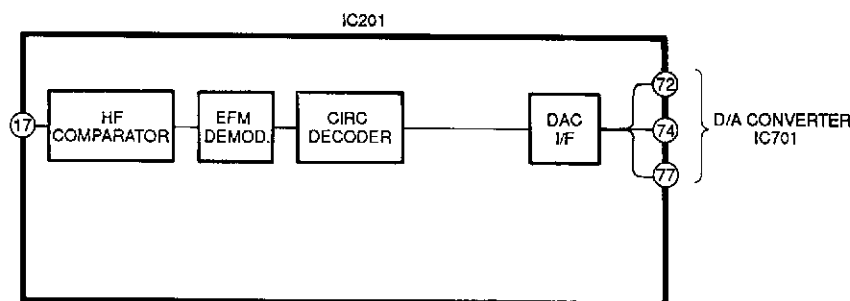

Fig. 8

4. 1-bit D/A Converter

Conventionally, high-precision D/A conversion was mainly carried out using resistor ladder systems. There was, however, one main drawback with these systems, which was that zero cross distortion was likely to be generated. To achieve production of a high-precision D/A converter with a minimum amount of zero cross distortion, it would be necessary to carry out complicated and bothersome processes such as laser trimming processing. In addition, use of such D/A converter would require a sampling-and-hold circuits(or de-glitcher circuit) and an intricate analog filter with special characteristics when mounting it.

To solve these difficulties, we used a 1-bit D/A converter with 3rd order noise shaping technology (IC701: MN 6471).

4-1. Features and Configuration of MN6471

- Features
1. No zero cross distortion
 2. No non linear distortion
 3. Built-in 4 times oversampling digital filter
 4. 2 channels (left and right) built in
 5. 4DAC configuration possible
 6. Single 5V power supply operation

The block diagram is shown in Fig. 9. The MN6471 is configured of a digital filter, a 3rd order noise shaping circuit, and a PWM.

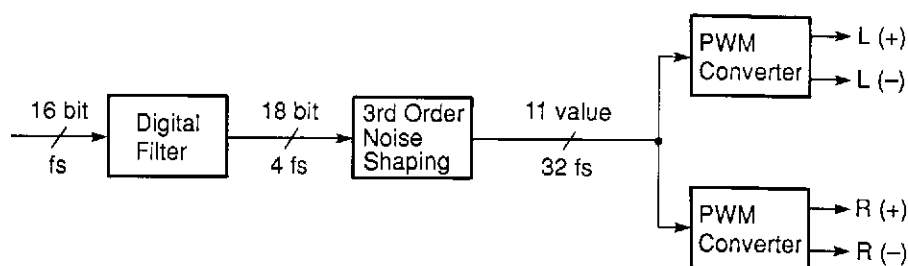

Fig. 9

4-2. Configuration of MN6471

Fig. 10 shows the configuration of the MN6471. The sampling frequency of the input data is expressed in f_s , so the 3rd order noise shaping circuit operates at $32f_s$. This means that a 32-times oversampling filter is required. In this LSI, however, oversampling is carried out first at $4f_s$ in the first digital filter, and following that, a 0 order hold takes place in the 3rd order noise shaping circuit. This enables conversion of the $4f_s$ signal to a $32f_s$ signal.

The digital filter, using $384f_s$ as clock signals, and the noise shaping section, uses $64f_s$, carry out time division processing on the data for the left and right channels. The PWM section, using $768f_s$ as a clock signal, carries out signal processing for the left and right channels independently.

In the noise shaping section, the 19-bit $32f_s$ signal is converted to 11 values and pulse width modulation (PWM) is carried out on these signals in the PWM section. D/A conversion is carried out in this way.

Following are the descriptions of the various blocks.

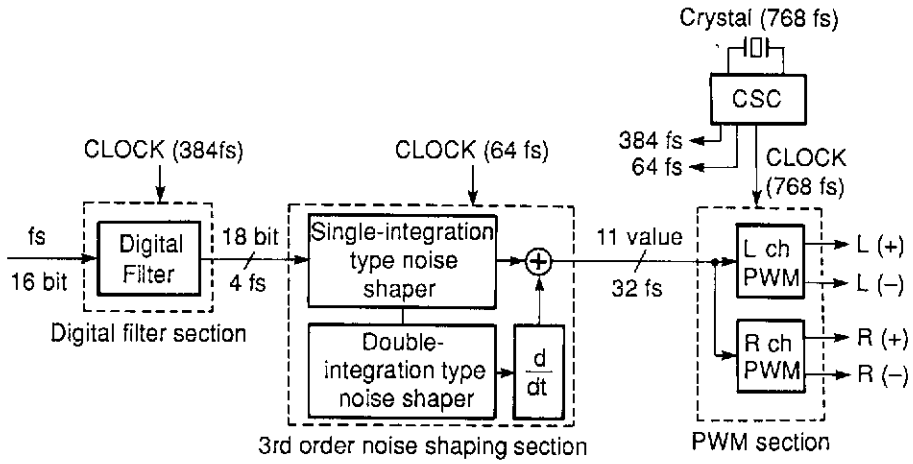

Fig. 10

5. Digital filter

Fig. 11 shows the signal data of an audio signal up to 20kHz that has been digitalized, along with the frequency distribution of the signal data. The graphs show the conditions for a sampling frequency of 44.1kHz, plus its doubled frequency, 88.2kHz, and its quadrupled frequency, 176.4kHz.

As the figure shows, for the same signal up to 20kHz, the noise portion of the digitalized signal component tends to shift toward the higher range of the signal if the sampling frequency is increased. However, at any sampling frequency, the volume of necessary audio signal information remains constant up to 20kHz. This allows certain important results to be derived; that is, if the information represented in section (a) is obtained, then it should be possible to create a signal in the form shown in (b) or (c).

When the noise caused by sampling shifts to the higher frequency range, as shown in (b) or (c), the low pass filter characteristic to eliminate noise during re-conversion to an audio signal need not be steep but can be rather gradual as shown. It is comparatively simple to provide a high audio quality low pass filter of such characteristic with little phase fluctuation or distortion.

The question now becomes how to make a signal sampled at 44.1kHz resemble one sampled at a much higher frequency. Fig. 12 shows the signal sequence sampled at the same 44.1kHz as in Fig. 11 and its frequency distribution.

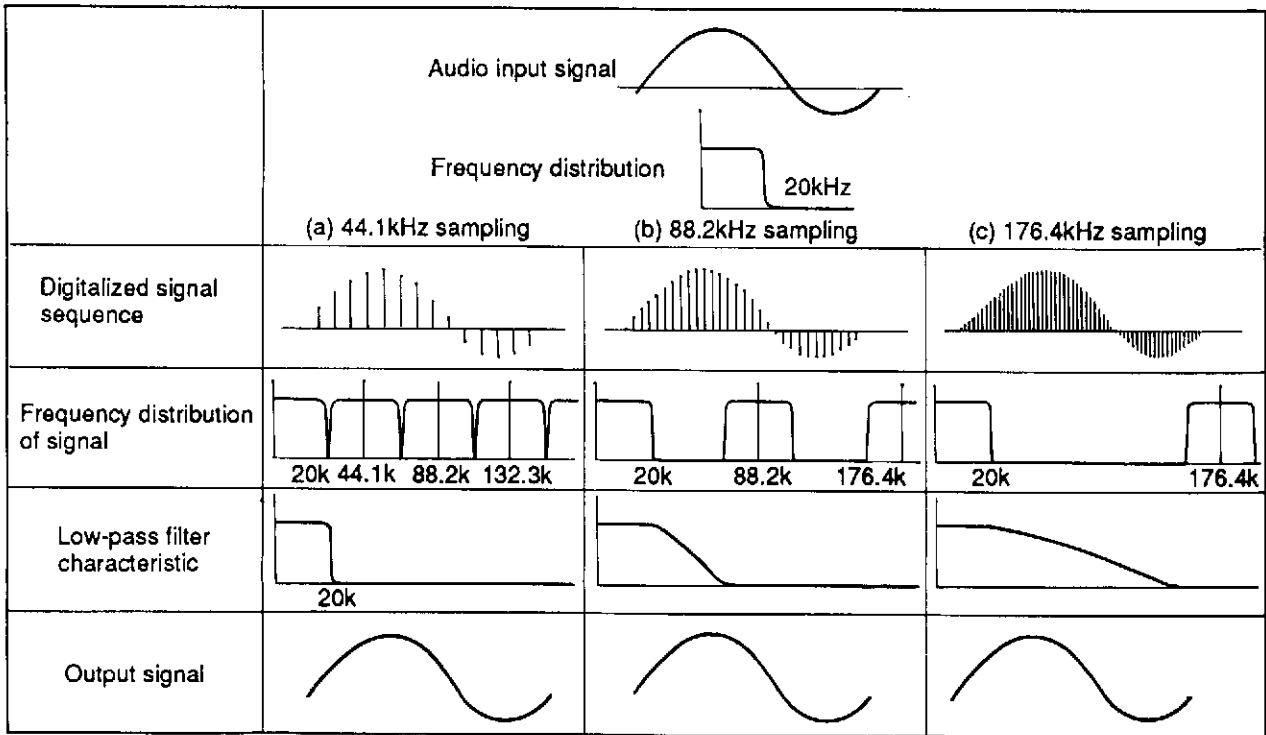

Fig. 11

If the frequency is to be doubled as the first step in increasing the sampling frequency of the signal, zero-level data is added between the data marked with X in Fig. 12(b). In the original signal sequence sampled at 44.1kHz, there are data only at the points of the sampling timing, while the intervals between those points have all been made zero-level. Introducing zero data in these intervals does not change the original data in any way, nor is the frequency distribution altered. Only the sampling frequency is doubled.

Passing this data in its modified form through a digital filter with the characteristic shown in Fig.10(c) causes the portion corresponding to NI to be eliminated, resulting in a signal sequence with the frequency distribution shown in (d). This signal sequence possesses exactly the same shape as that obtained for the signal in Fig. 11(b), sampled at 88.2kHz.

In other words, this method enables the sampling frequency to be doubled.

The digital filter used in this unit is a Finite Impulse Response type. Its circuit diagram is shown in Fig. 13.

The sampling frequency of this unit has been quadrupled, and the phase characteristic has been improved by using a softer analog low-pass filter.

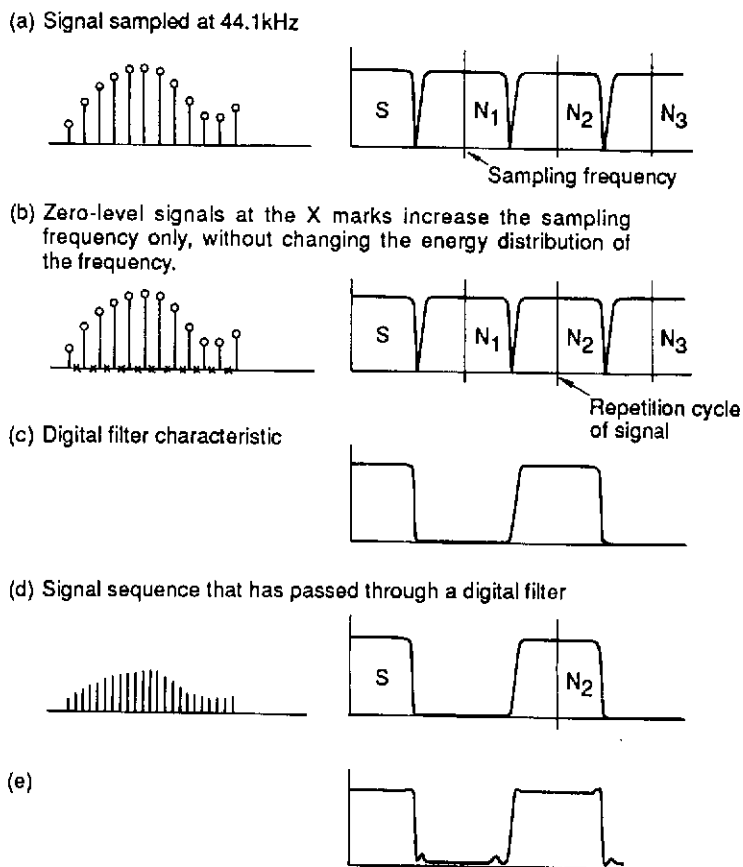

Fig. 12

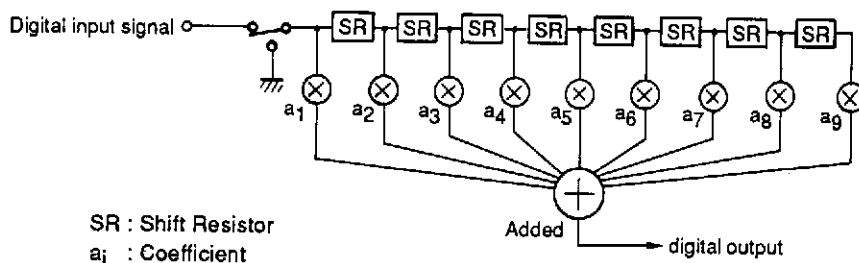

Fig. 13

6. Noise shaper

a) Single-integration noise shaper

The block diagram is shown in Fig. 14.

According to the figure, the relation between input X and output Y is as follows:

$$Y = X + (1 - Z^{-1}) Vq \dots\dots\dots (1)$$

The quantization error Vq is a random value, and (1-Z⁻¹) expresses the differential characteristic. Thus, according to equation (1), the spectrum of the quantization error Vq for the single-integration noise shaper has a characteristic of 6dB/oct, and the lower the frequency is, the greater the attenuation becomes. (This is because the noise distribution can be changed by the noise shaper).

b) Double-integration noise shaper

The block diagram is shown in Fig. 15.

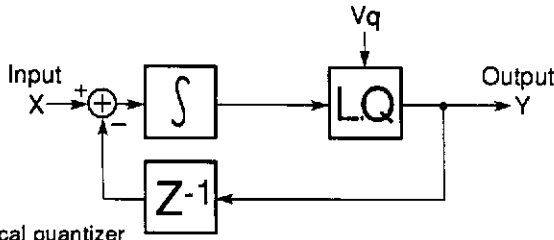

Fig. 14

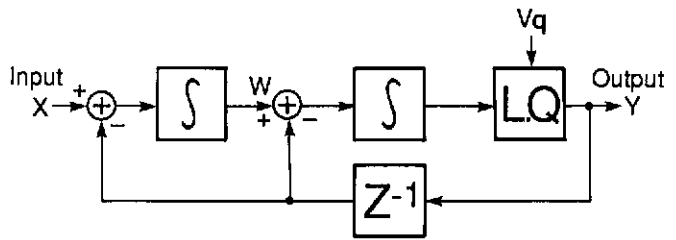

Fig. 15

LQ : Local quantizer
 Z⁻¹ : Delay
 Vq : Quantization error
 ∫ : Integrator

In Fig. 15, the path to the output seen from W has a configuration identical to that of the single-integration noise shaper, so that relation between W and Y is:

$$Y = W + (1 - Z^{-1}) Vq \dots\dots\dots (2)$$

The relation between X and Y is:

$$W = \frac{1}{1 - Z^{-1}} (X - Z^{-1}Y) \dots\dots\dots (3)$$

And the result obtained from above equations (2) and (3) is:

$$Y = X + (1 - Z^{-1})^2 Vq \dots\dots\dots (4)$$

Comparison with equation (1) shows that the term (1 - Z⁻¹) is a square of itself. In other words, with the double-integration noise shaper, the spectrum of the quantization error Vq is attenuated at a slope of 12dB/oct.

Fig. 16 shows the output spectrum of the noise shaper.

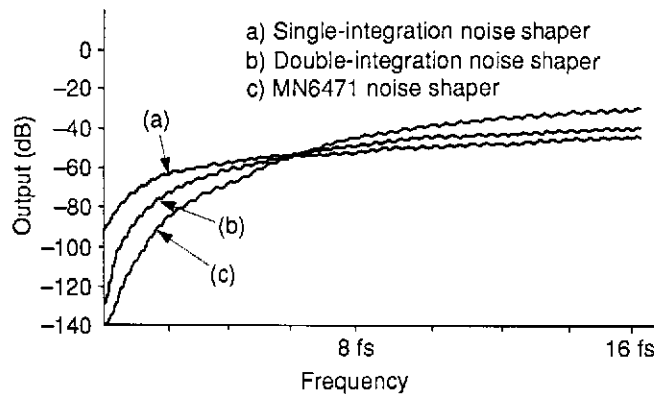

Fig. 16

6-2. 3rd order noise shaper

The block diagram of the 3rd order noise shaper is shown in Fig. 17.

This configuration shows that the first stage uses a single-integration noise shaper and the following stage uses a double-integration noise shaper. The quantization error of the first stage is input at the second stage.

In this configuration, single-integration and double-integration noise shapers are connected at several stages, and the quantization error of the previous stage is quantified again at the following stage, so that the quantization error included in the output of the previous stage is negated. In this way, compensation is carried out.

In this noise shaping circuit, the input is expressed as X, the output as Y, and the re-quantized error as Vq, and their relation for

8. Audio Circuit

Fig. 19 shows a block diagram of the audio circuit.

The output from pin 21 (OUT R (-)) and pin 18 (OUT R (+)) of the IC701 D/A converter MN6471 passes through the buffer circuit of the discrete circuit configured of Q604, 608, and 612; and Q602, 606, and 610 respectively. It is then input to the differential input amplifier, which is symmetrical in the up and down directions, of the discrete circuit configured of the following stage, which includes Q310, 312, 302, 304, 306, 308, 314, and 316. The output undergoes differential synthesis in this circuit, and after synchronous-phase noise has been eliminated, the resulting signal is output to the low-pass filter of the discrete circuit configuration of the following stage as an audio signal with very little 2nd order high-frequency distortion. Q605 and 609 (left channel), and Q606 and 610 (right channel) are an inverted darlington buffer circuit, while Q601 (left channel) and Q602 (right channel) are a FET-controlled constant-current circuit. Q309 and 311 (left channel) and Q310 and 312 (right channel) are, similarly, a FET-controlled constant-current circuit. Fig. 20 shows the buffer circuit and the differential input amplifier (left channel only).

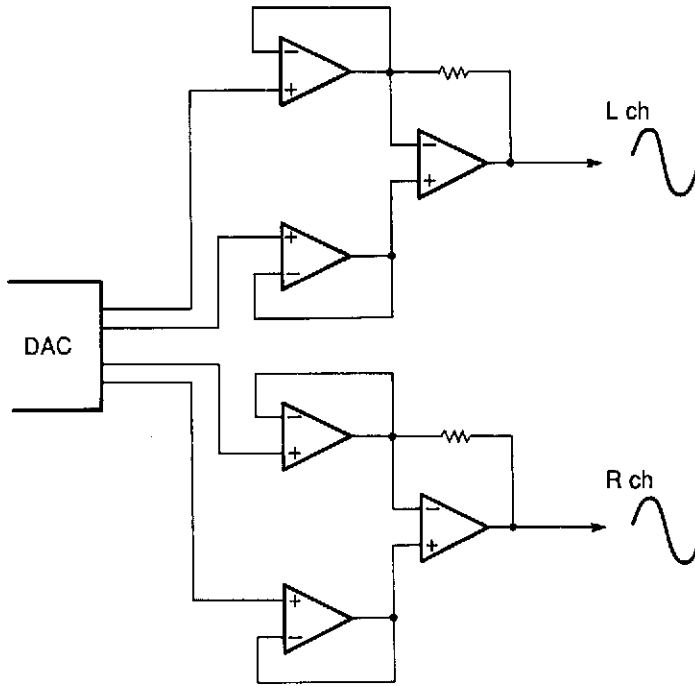

Fig. 19

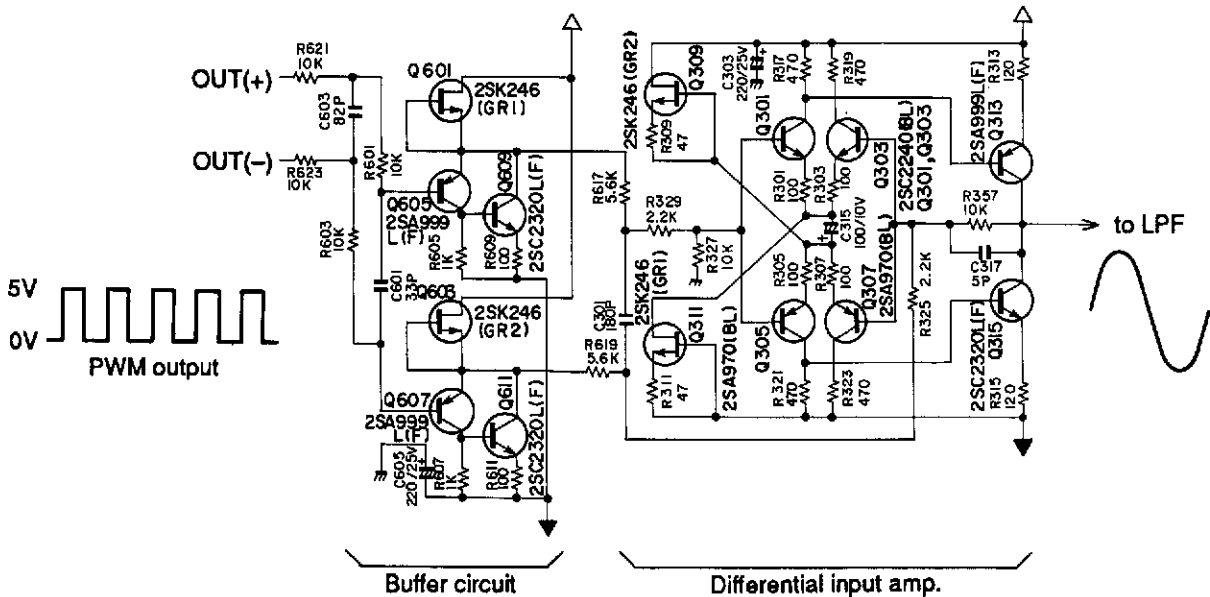

Fig. 20

9. Low-pass filter

Fig. 21 shows a final-stage circuit which includes a low-pass filter and other elements.

The emphasis data from the disc is output through the EMP terminal (pin 1) of IC201. When a disc to which emphasis is applied is played back, this terminal is set high and Q202 turns on. Following this, Q317 (left channel) and Q318 (right channel) are also turned on.

Then connecting C305 (left channel) and C306 (right channel) to the ground provides the de-emphasis characteristic. The portion of Fig. 21 enclosed by the broken line is a 3rd-order active LPF. This LPF causes noise in the high range to be cut. Q321 and Q323 (left channel) and Q322 and Q324 (right channel) are buffer circuits of inverted darlington configuration. Q319 and Q320 are FET controlled constant current circuits.

Q325, Q326, Q51 and Q56 are power muting circuits.

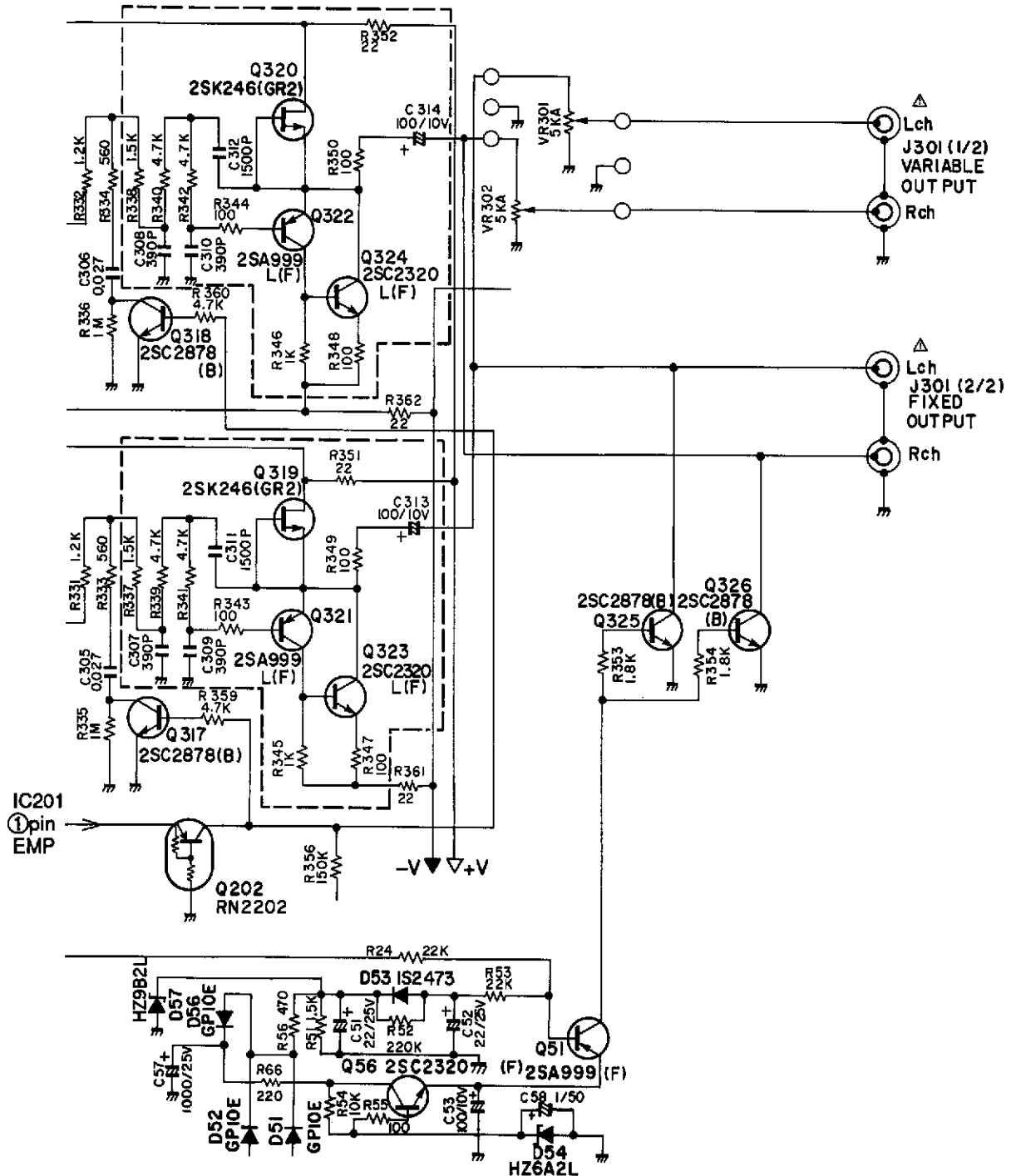
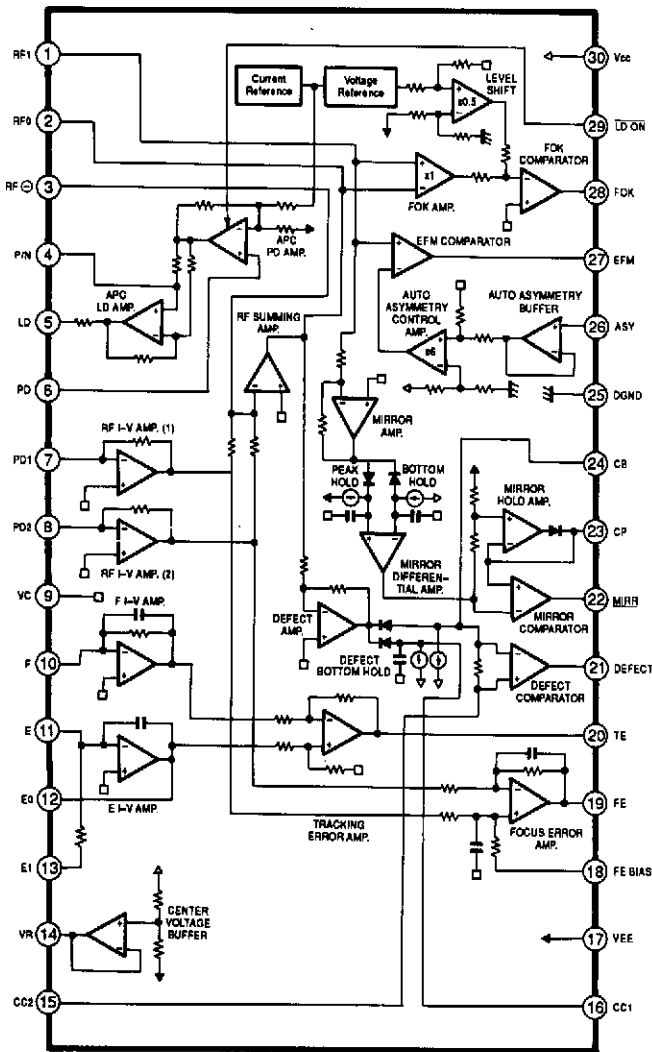

Fig. 21

IC BLOCK DIAGRAM

IC101 : CXA1081S
RF Amp.



IC102
M51564P
Optical Pick-up Servo Control

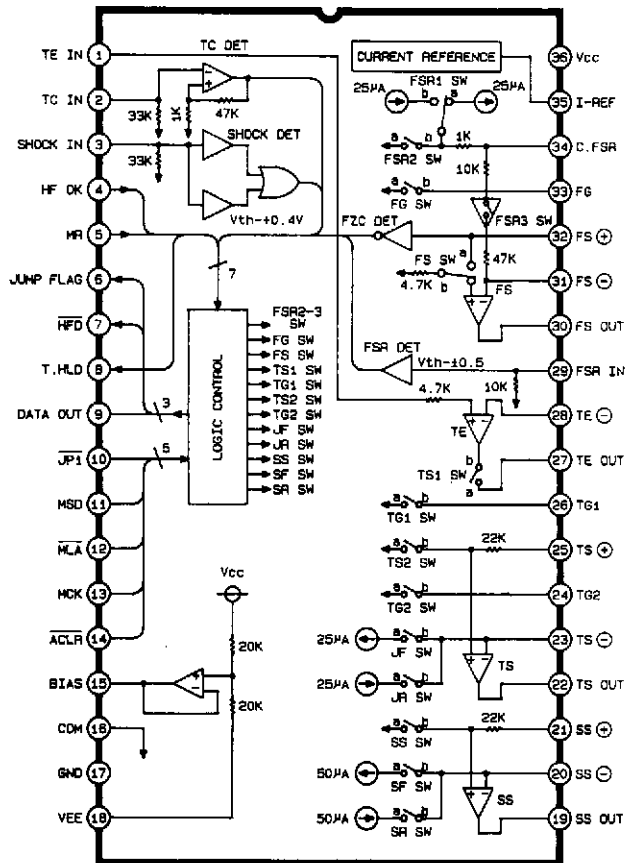

IC103 : LA6520
3 channel Power OP-Amp.

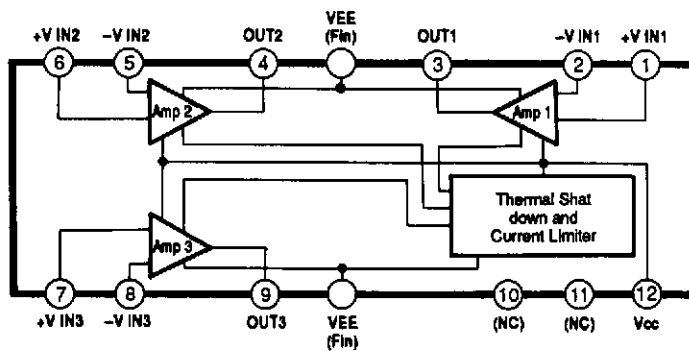

IC201 : M50423FP
Digital Signal Processor

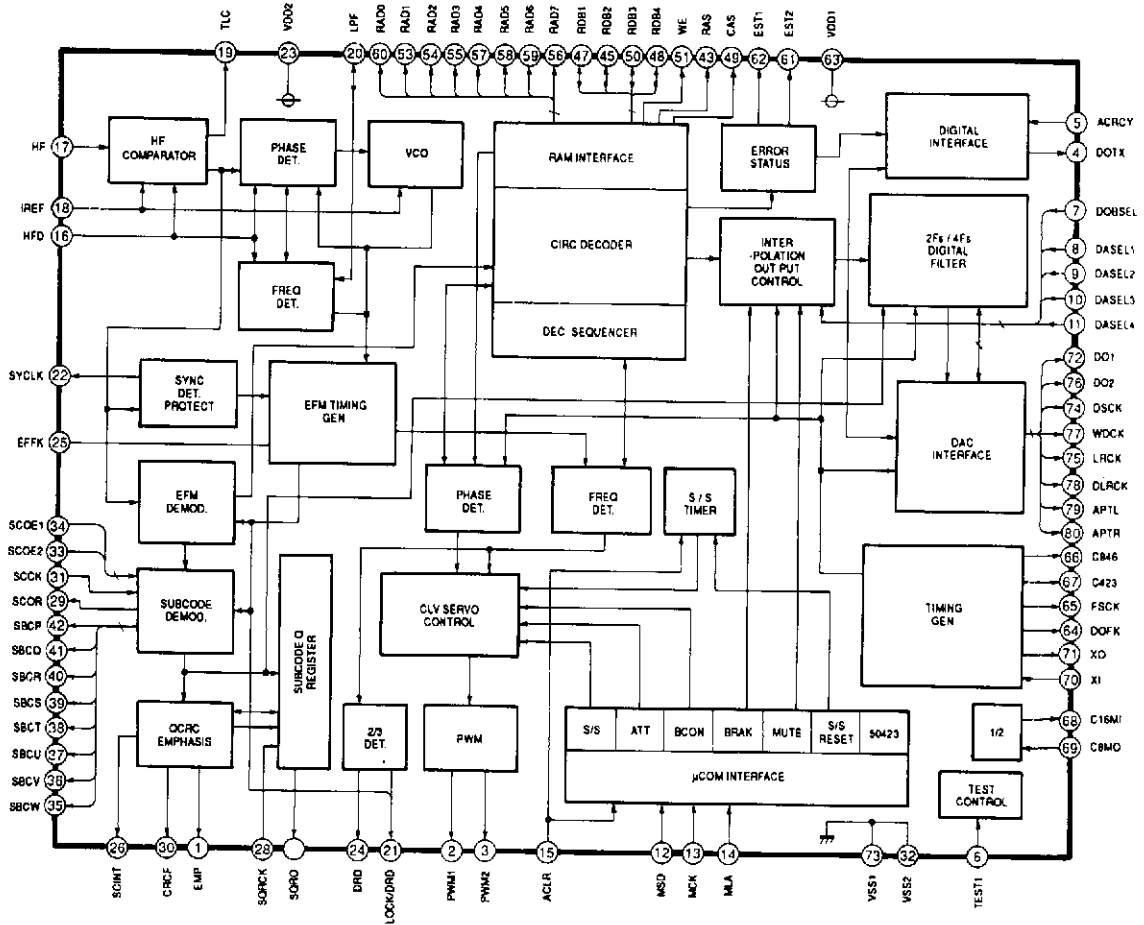

IC202
M5M4416P
65536-Bit (16384-Word by 4-Bit)
Dynamic RAM

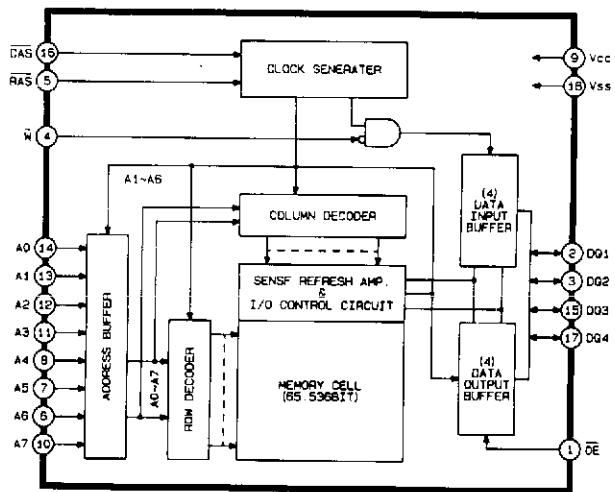

IC203 : LA6515
2 channel Power OP-Amp.

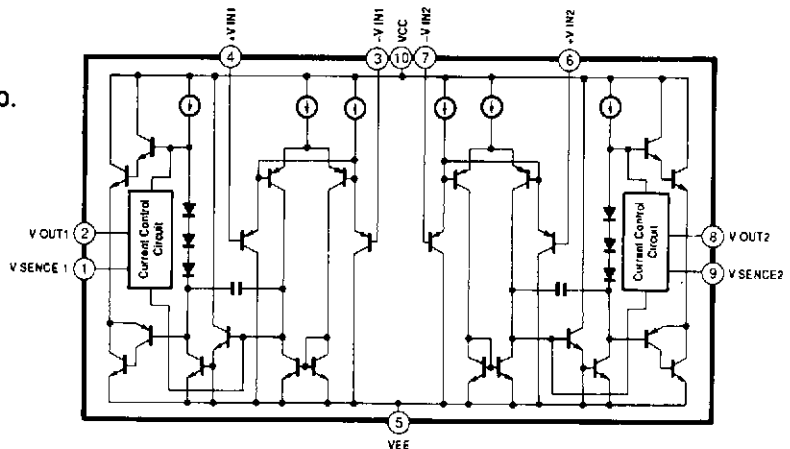

IC401 : M50957
Microcomputer

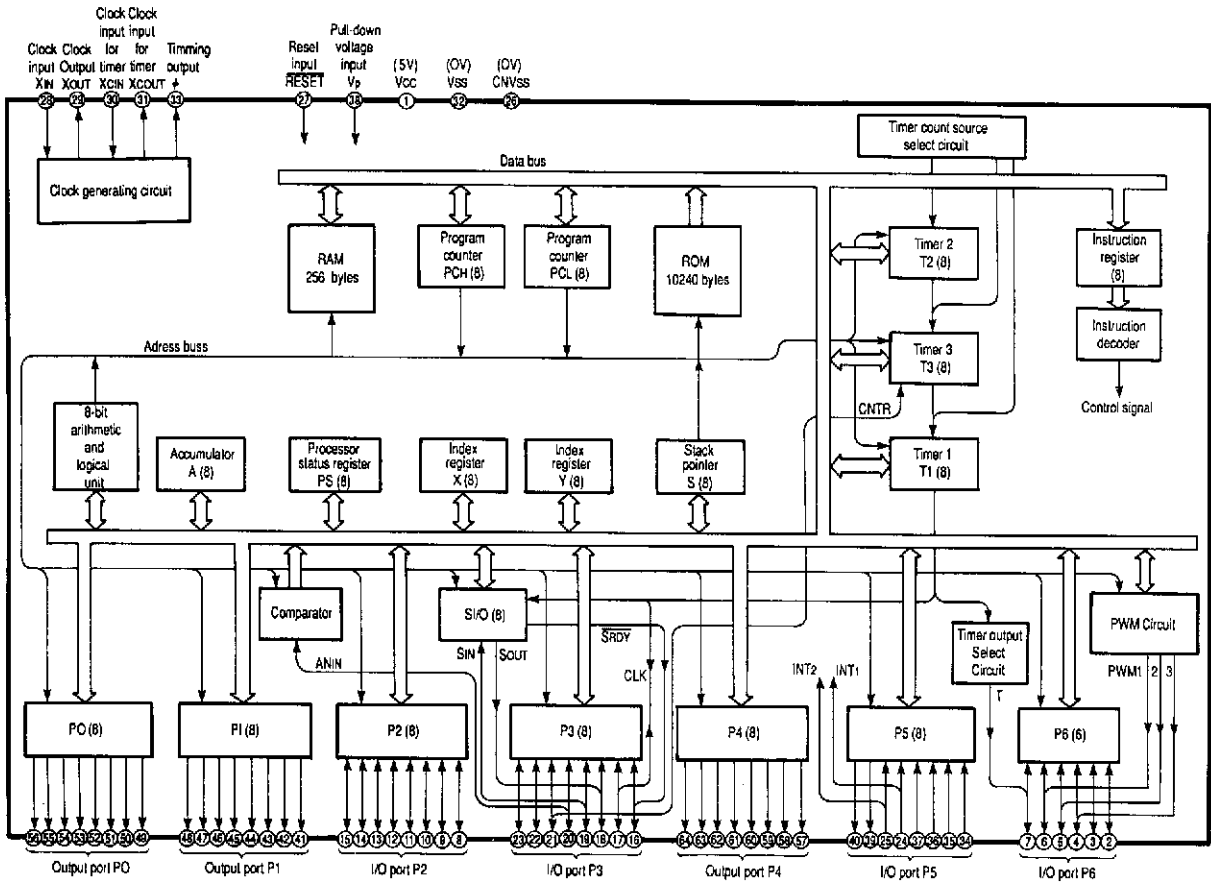

IC501 : NJM4556D
Headphone Amp.

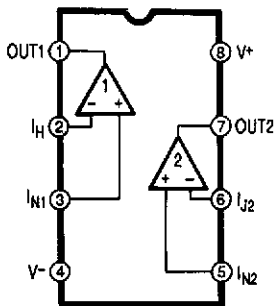

IC701 : MN6471M
Digital Filter & D/A Converter

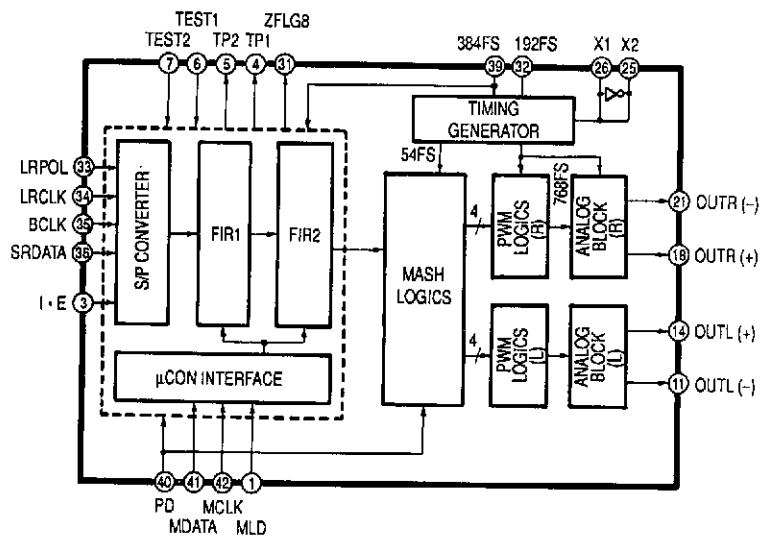

CD MECHANISM
EXPLODED VIEW

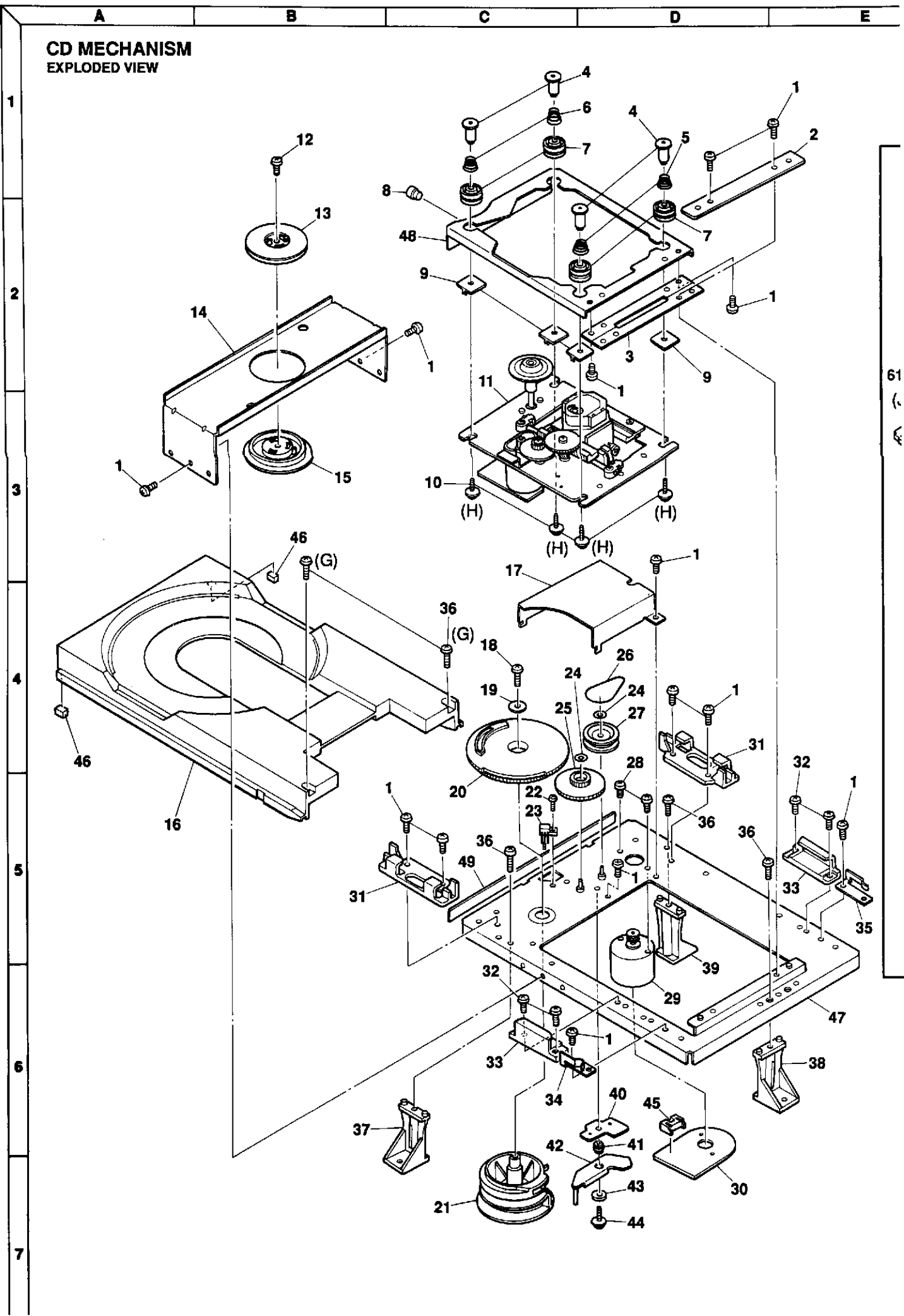

61
(
/

1
2
3
4
5
6
7

E F G

PARTS LIST

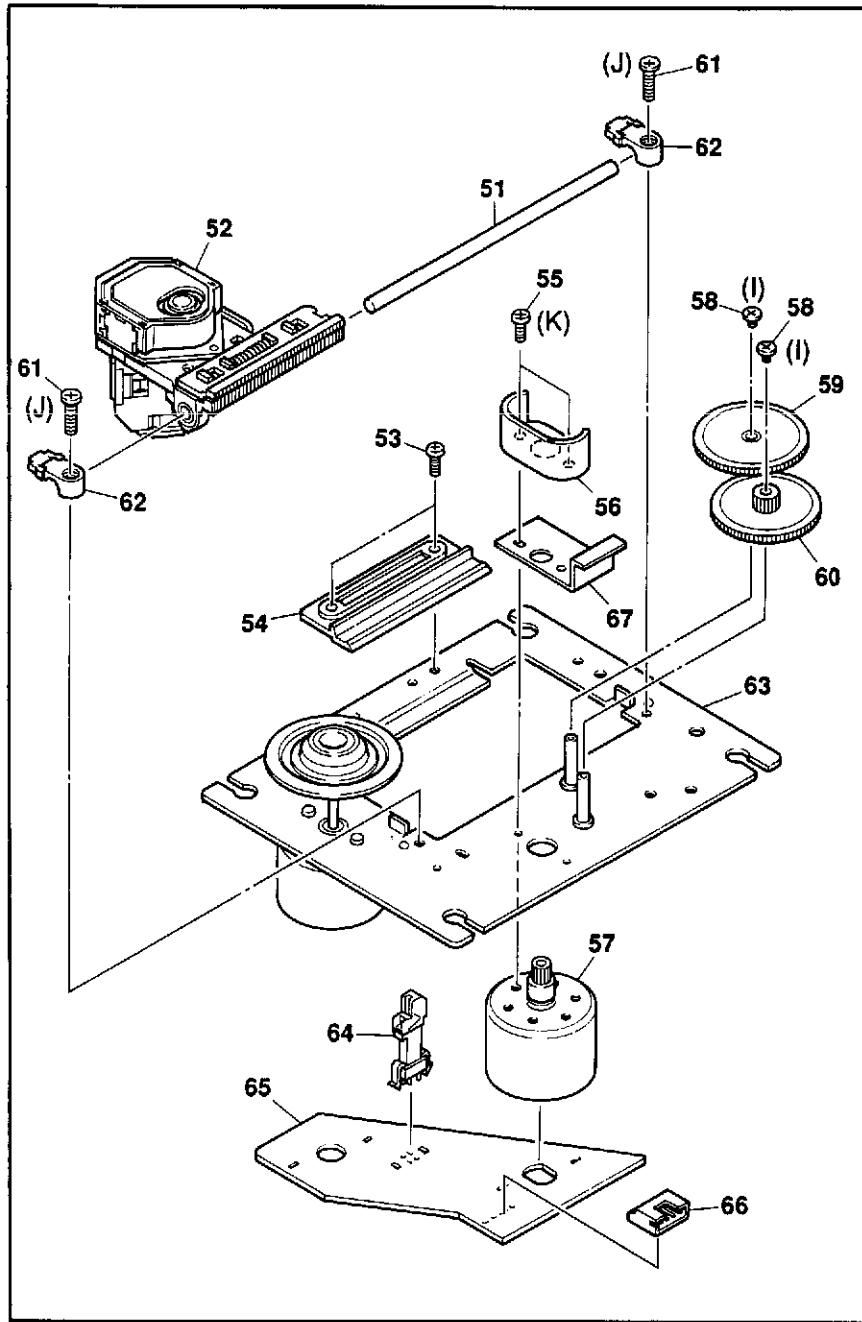

Ref. No.	Part No.	Description
1	7-685-862-(01)	SCREW (+)(2.6x6mm)
2	2-642-170-(01)	HINGE HOLDER
3	2-642-164-(01)	HINGE
4	2-642-160-(01)	SHAFT
5	2-642-137-(02)	COIL SPRING (B)
6	2-642-139-(02)	COIL SPRING (A)
7	2-642-158-(01)	INSULATOR (C)
8	2-642-169-(01)	ROLLER
9	2-642-159-(01)	PLATE (T)
10	2-642-142-(01)	SCREW
11	8-848-097-(01)	CD PLAYER SUB UNIT ASS'Y
12	7-685-532-(19)	SCREW (+)(2.6x5mm)
13	X-2642-108-(1)	MAGNET ASS'Y
14	2-642-165-(01)	CHACK CHASSIS
15	2-642-432-(01)	CHACKING PULLEY
16	2-642-156-(01)	TRAY
17	2-642-149-(02)	GEAR COVER
18	7-685-535-(19)	SCREW (+)(2.6x10mm)
19	4-812-554-(01)	WASHER
20	2-642-154-(02)	DRIVE GEAR
21	2-642-153-(01)	CONTROL CAM
22	7-685-851-(01)	SCREW (+)(2x4mm)
23	1-571-312-(11)	LEAF SWITCH
24	3-558-706-(21)	LOCK WASHER
25	2-642-148-(01)	CENTER GEAR
26	3-653-387-(01)	LM BELT
27	4-913-731-(01)	LOADING PULLEY
28	7-621-775-(00)	SCREW (+)(2.6x3mm)
29	X-2641-336-(1)	MOTOR ASS'Y
30	1-624-793-(21)	MOTOR P. C. BOARD
31	2-642-161-(01)	TRAY HOLDER, FRONT
32	7-685-781-(01)	SCREW (+)(2x4mm)
33	2-642-162-(02)	TRAY HOLDER, REAR
34	2-642-146-(01)	TRAY GUIDE, RIGHT
35	2-642-147-(01)	TRAY GUIDE, LEFT
36	7-685-547-(19)	SCREW (+)(3x10mm)
37	2-642-178-(01)	HOLDER, RIGHT
38	2-642-177-(01)	HOLDER, REAR
39	2-642-176-(01)	HOLDER, LEFT
40	2-642-173-(01)	LINK PLATE
41	2-642-133-(02)	BOSS
42	X-2642-107-(1)	STOPPER LINK ASS'Y
43	2-642-172-(01)	SPACER
44	3-319-501-(11)	SCREW (+)(2.6x8mm)
45	1-564-721-(11)	CONNECTOR, 5 PIN
46	2-642-125-(01)	DAMPER
47	X-2642-106-(1)	MAIN CHASSIS ASS'Y
48	X-2642-105-(1)	SUB CHASSIS ASS'Y
49	2-642-157-(03)	FRONT TAPE
51	4-910-431-(02)	SLIDE SHAFT
52	8-848-046-(51)	PICK-UP ASS'Y
53	2-641-386-(01)	SPECIAL SCREW (2x5mm)
54	2-641-443-(02)	SLIDE HOLDER
55	7-621-255-(35)	SCREW (+)(2x5mm)
56	2-641-434-(01)	GEAR COVER
57	X-2641-344-(1)	SLIDE MOTOR ASS'Y
58	3-303-809-(31)	SPECIAL SCREW (M1.7x3mm)
59	2-641-404-(02)	GEAR (A)
60	2-641-403-(06)	GEAR (B)
61	2-641-447-(01)	SCREW (+)(2.6x8mm)
62	2-641-448-(02)	SHAFT CLAMP
63	X-2641-348-(1)	DISC MOTOR ASS'Y
64	1-570-822-(22)	LEAF SWITCH
65	1-628-263-(11)	MOTOR P. C. BOARD
66	1-564-720-(11)	CONNECTOR, 4 PIN
67	2-641-371-(01)	STOPPER

GENERAL UNIT
EXPLODED VIEW

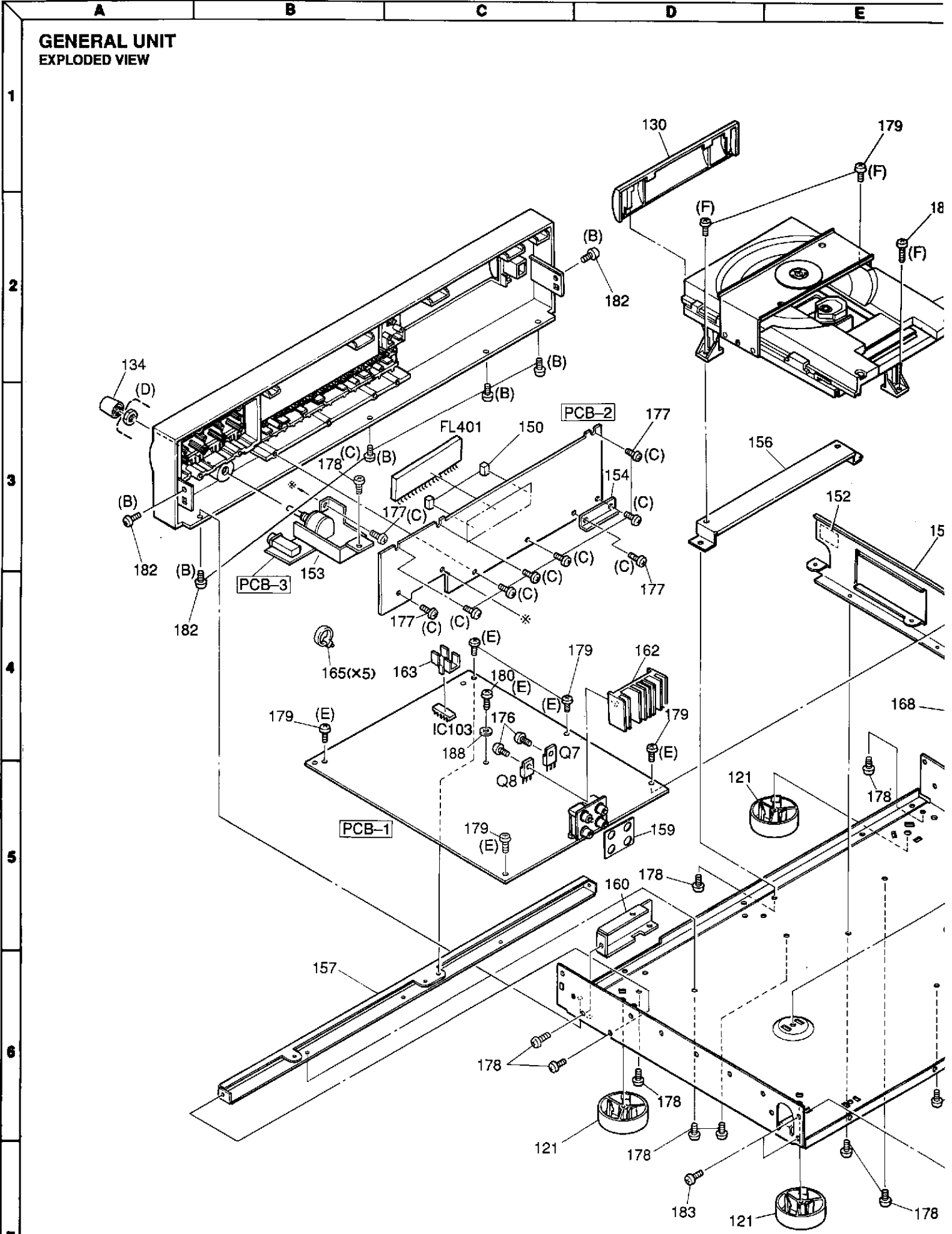

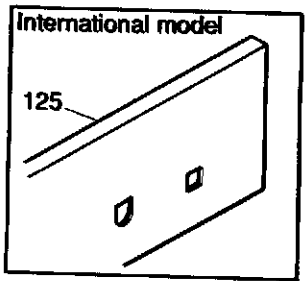
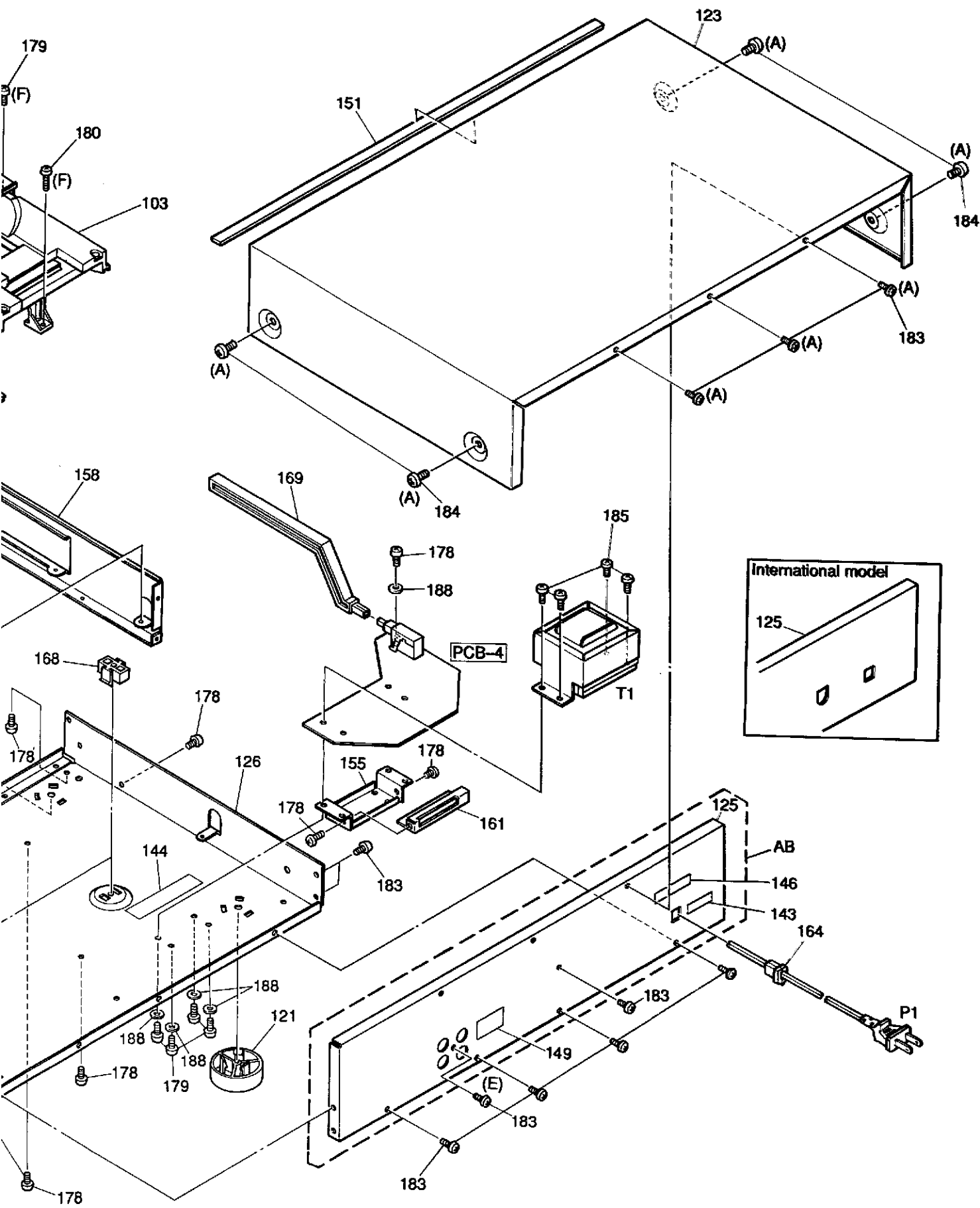

PARTS LIST

Ref. No.	Part No.	Description	Ref. No.	Part No.	Description
AA	A442-HD7500A	PANEL, FRONT ASSY UA I	145	1756-12101	LABEL I IB NB BB
AA	A442-HD7500B	PANEL, FRONT ASSY BK	146	1756-CSA	LABEL UA BK
AA	A442-HD7500C	PANEL, FRONT ASSY IB	147	1756-11601	LABEL UA BK
AA	A442-HD7500D	PANEL, FRONT ASSY NB	149	1756-11801	LABEL UA BK I IB
AA	A442-HD7500E	PANEL, FRONT ASSY BB	150	2114-85143	BUSHING, FL (x2)
AB	A424-HD7500A	CABI BACK, REAR ASSY UA BK	151	2111-11769	FELT, CABINET TOP
AB	A424-HD7500B	CABI BACK, REAR ASSY I	152	2111-1197	FELT, CD MECHA
AB	A424-HD7500C	CABI BACK, REAR ASSY IB	153	2216-7186	SHIELD PLATE, PCB-3
AB	A424-HD7500D	CABI BACK, REAR ASSY NB	154	2216-7187	SHIELD PLATE, PCB-2
AB	A424-HD7500E	CABI BACK, REAR ASSY BB	155	2219-8262	METAL FITTG, TRANS
Q25	1756-11802	LABEL I IB BB	156	2219-8261	METAL FITTG, CD MECHA
Q32	1751-03708	LABEL, SET I IB BB	157	2219-8263	METAL FITTG, HORIZONTAL
103	3119-01201	CD MECHA	158	2219-8264	METAL FITTG, VERTICAL
109	1117-78	SERIAL LABEL	159	2219-7189	METAL FITTG, RCA PIN JACK
121	1319-02201	LEG (x4)	160	2219-8280	METAL FITTG, PCB-3
123	1414-14501	CABINET, TOP	161	2219-8282	METAL FITTG
125	1424-29505	CABI BACK, REAR UA BK	162	2222-7215	HEAT SINK, Q7/Q8
125	1424-29508	CABI BACK, REAR I IB BB	163	2222-7264	HEAT SINK, IC103
125	1424-29509	CABI BACK, REAR NB	164	2240-364	HOLDER, AC CORD
126	1424-29602	CABI BACK, BOTTOM	165	2240-R0101	HOLDER (x5)
129	1442-22001	PANEL, FRONT UA I	168	2360-7018	BOSS, SPECIAL (x2)
129	1442-22002	PANEL, FRONT BK IB NB BB	169	2601-7187	SHAFT, POWER SWITCH
130	1452-08302	LID, MECHA UA I	171	2651-2101732	SPRING (x2)
130	1452-08301	LID, MECHA BK IB NB BB	176	2327-R0130082	SCREW (+)(x2)(3x8mm)
131	1511-19803	PLATE, FL FILTER	177	2347-R0126082	SELF-TAPPING SCREW (+)(x9)(2.6x8mm)
132	1532-17502	WINDOW, FRONT	178	2347-R0130062	SELF-TAPPING SCREW (+)(x14)(3x8mm)
134	1632-19803	ROTARY KNOB, OUTPUT LEVEL UA I	179	2347-R0130082	SELF-TAPPING SCREW (+)(x12)(3x8mm)
134	1632-19801	ROTARY KNOB, OUTPUT LEVEL BK IB NB BB	180	2347-R0130122	SELF-TAPPING SCREW (+)(x2)(3x12mm)
135	1662-52103	PUSH BUTTON, PLAY, PAUSE, STOP, SKIP, SEARCH UA I	182	2347-R0130064	SELF-TAPPING SCREW (+)(x6)(3x8mm)
135	1662-52101	PUSH BUTTON, PLAY, PAUSE, STOP, SKIP, SEARCH BK IB NB BB	183	2347-R0130084	SELF-TAPPING SCREW (+)(x12)(3x8mm)
136	1662-52202	PUSH BUTTON, FUNCTION UA I	184	2347-R0140064	SELF-TAPPING SCREW (+)(x4)(4x6mm)
136	1662-52201	PUSH BUTTON, FUNCTION BK IB NB BB	185	2347-R0140082	SELF-TAPPING SCREW (+)(x4)(4x8mm)
137	1662-52003	PUSH BUTTON, POWER UA I	186	2347-R0130104	SELF-TAPPING SCREW (+)(3x10mm)
137	1662-52001	PUSH BUTTON, POWER BK IB NB BB	188	2401-035	WASHER, METAL (x6)
138	1662-52004	PUSH BUTTON, OPEN/CLOSE UA I	P1	4161-03601202	CORD W/PLUG UA BK
138	1662-52002	PUSH BUTTON, OPEN/CLOSE BK IB NB BB	P1	4161-03701220	CORD W/PLUG I IB
139	1662-36303	PUSH BUTTON, 10-KEY (x11) UA I	P1	4161-00401192	CORD W/PLUG NB
139	1662-36301	PUSH BUTTON, 10-KEY (x11) BK IB NB BB	T1	4161-04100	CORD W/PLUG BB
143	1341-5568	NAME PLATE UA BK	T1	5584-S6301	XFORMER, POWER BK
144	1756-03305	LABEL UA BK I IB	T1	5584-S6302	XFORMER, POWER I IB
145	1756-09602	LABEL UA BK	T1	5584-S6303	XFORMER, POWER NB

EXPLODED VIEW

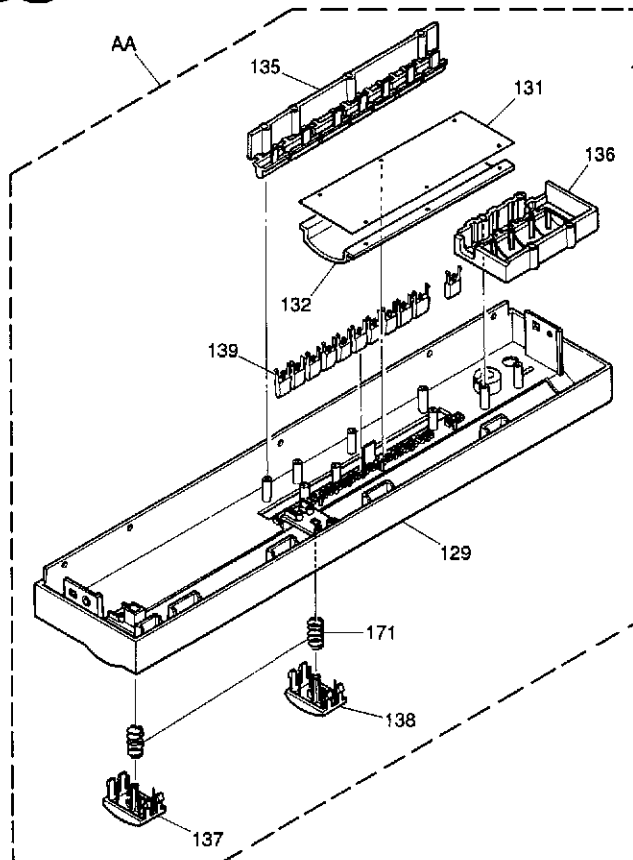

PACKAGE

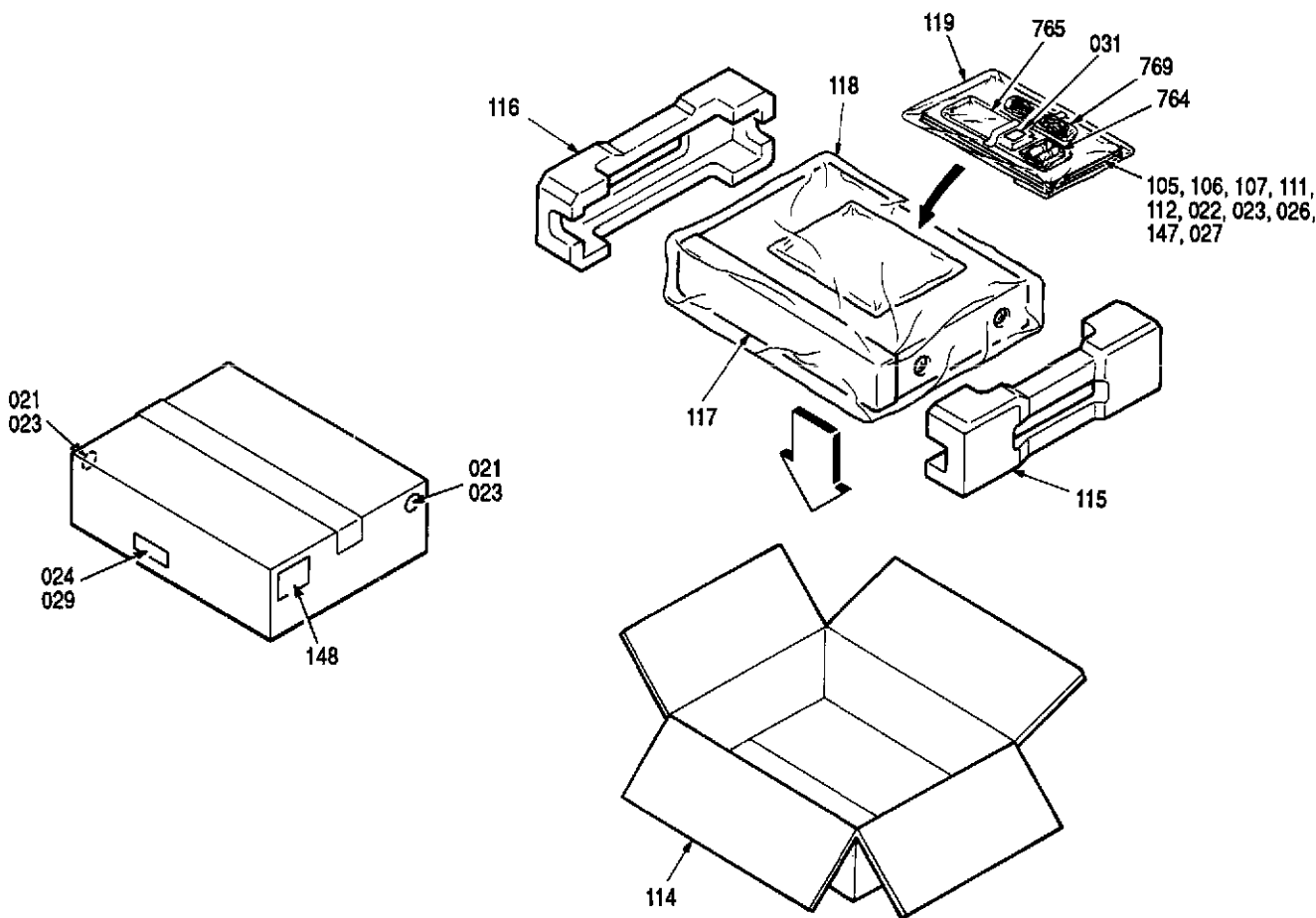

Ref. No.	Part No.	Description	Ref. No.	Part No.	Description
021	1756-03113	LABEL (x2) (NB)	111	1119-047	ATTACH SHEET, GUARANTY CARD (UA BK)
022	1113-OC	OWNER CARD (NB)	112	1119-0137	ATTACH SHEET, SERVICE GUIDE (UA BK)
023	1756-03108	LABEL (x2) (I IB)	114	1221-7037144	CARTON BOX (UA)
023	1116-GC	GUARANTY CARD (NB)	114	1221-26903	CARTON BOX (I)
023	1756-03111	LABEL, (BB)	114	1221-26904	CARTON BOX (IB BB)
024	1756-06303	LABEL (I IB BB)	114	1221-7047144	CARTON BOX (BK NB)
026	1111-F30253	OWNER GUIDE, SAFETY GUIDE (I IB)	115	1222-7359	CUSHION, R
027	1111-J30319	OWNER GUIDE, AUSTRALIA ADDENDUM SHEET (BB)	116	1222-7360	CUSHION, L
029	1756-08501	LABEL 240V (BB)	117	1223-11729	SOFT SHEET, FRONT PANEL
031	1751-20301	LABEL (I IB BB)	118	1241-C1491	POLYETHY BAG, SET
105	1111-J30309	OWNER GUIDE, IB (UA BK)	119	1241-R0123350	POLYETHY BAG, IB
105	1111-F30310	OWNER GUIDE, IB (I IB)	147	1756-11601	LABEL (BK)
105	1111-J2053	OWNER GUIDE, IB (NB)	148	1756-11701	LABEL (UA BK)
106	1119-01201	ATTACH SHEET (UA BK)	764	4191-0355	BATTERY, DRY
107	1113-717004	OWNER CARD (UA BK)	765	6142-05502	REMOTE CONTROL ASSEMBLY (I IB BB)
			765	6142-05501	REMOTE CONTROL ASSEMBLY (UA BK NB)
			769	4161-04601102	CORD W/PLUG, RCA TYPE

A

B

C

D

E

P. C. BOARDS

1

OUTPUT
VARIABLE FIX

PCB-1 MAIN P. C. BOARD

2

3

4

EF BALANCE
ADJUSTMENT

FOCUS OFFSET
ADJUSTMENT

5

6

7

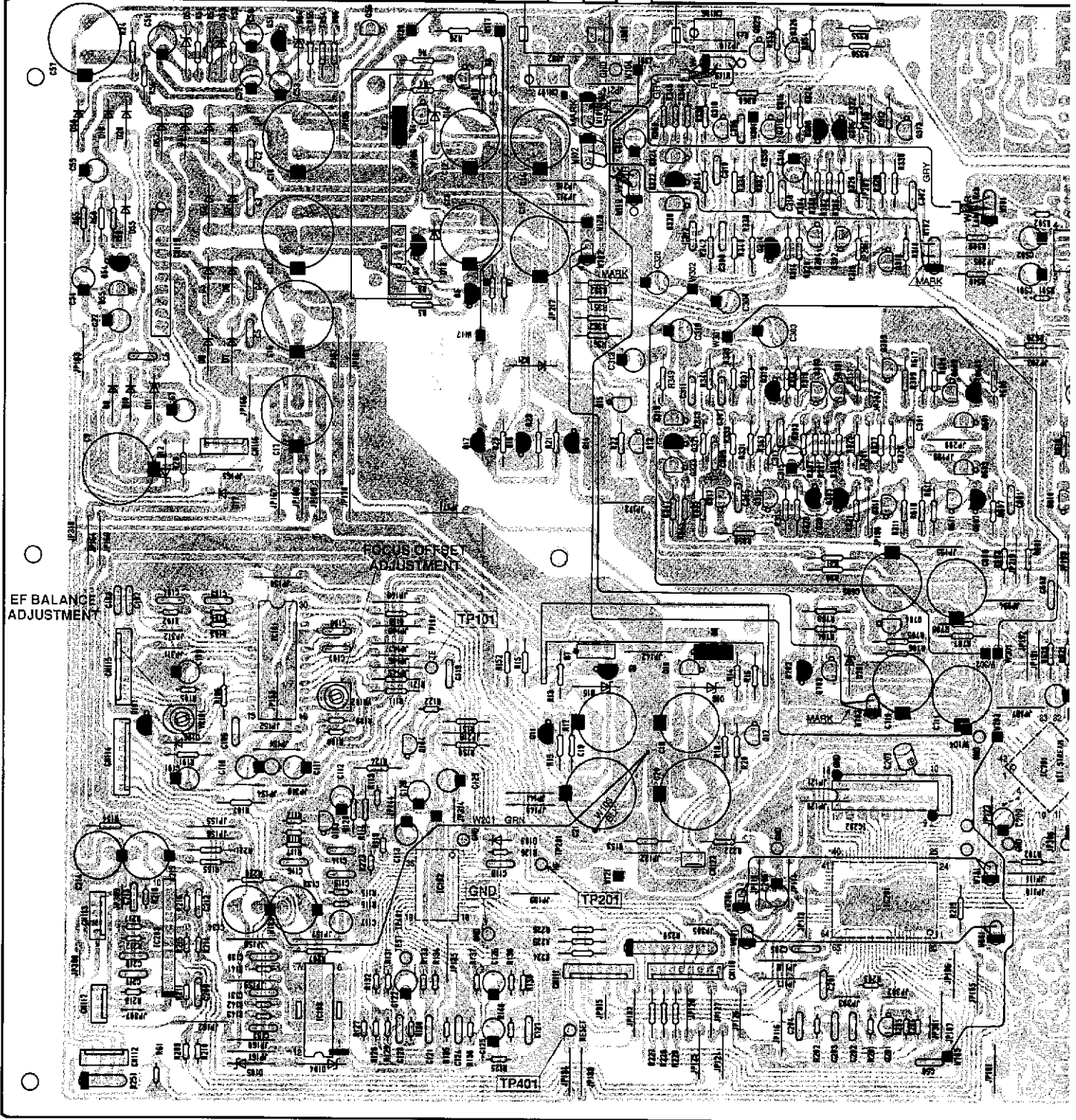

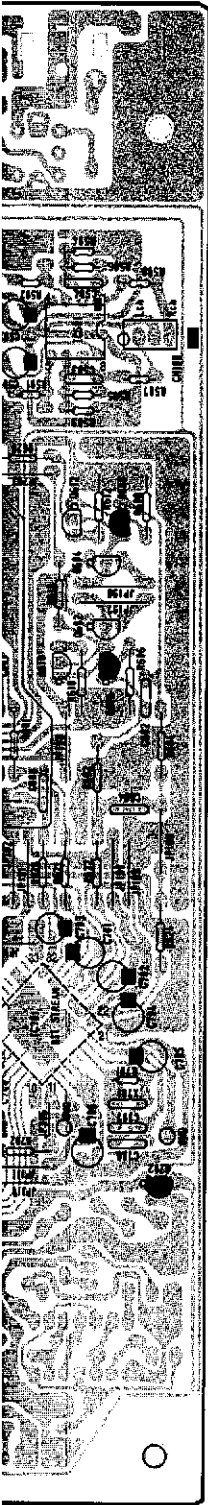

PCB-2 FRONT P. C. BOARD

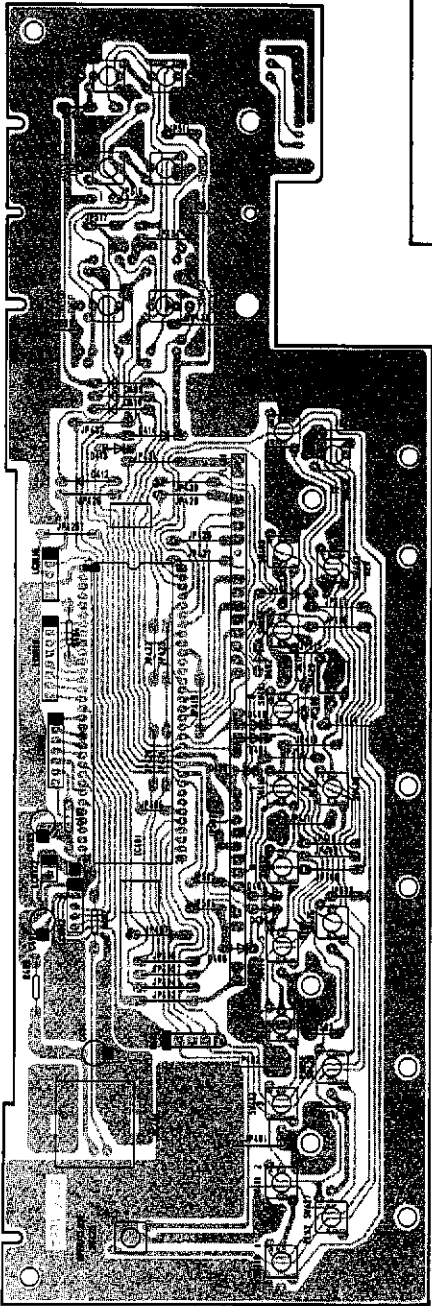

PCB-4 POWER SWITCH P. C. BOARD

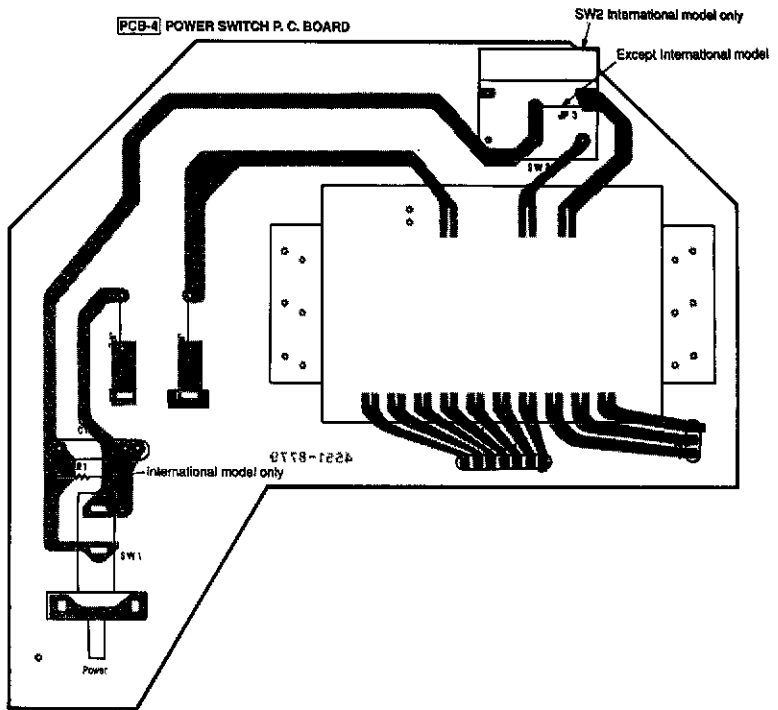

PCB-3 OUTPUT LEVEL & JACK P. C. BOARD
HEADPHONES

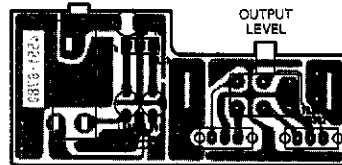

BLOCK DIAGRAM

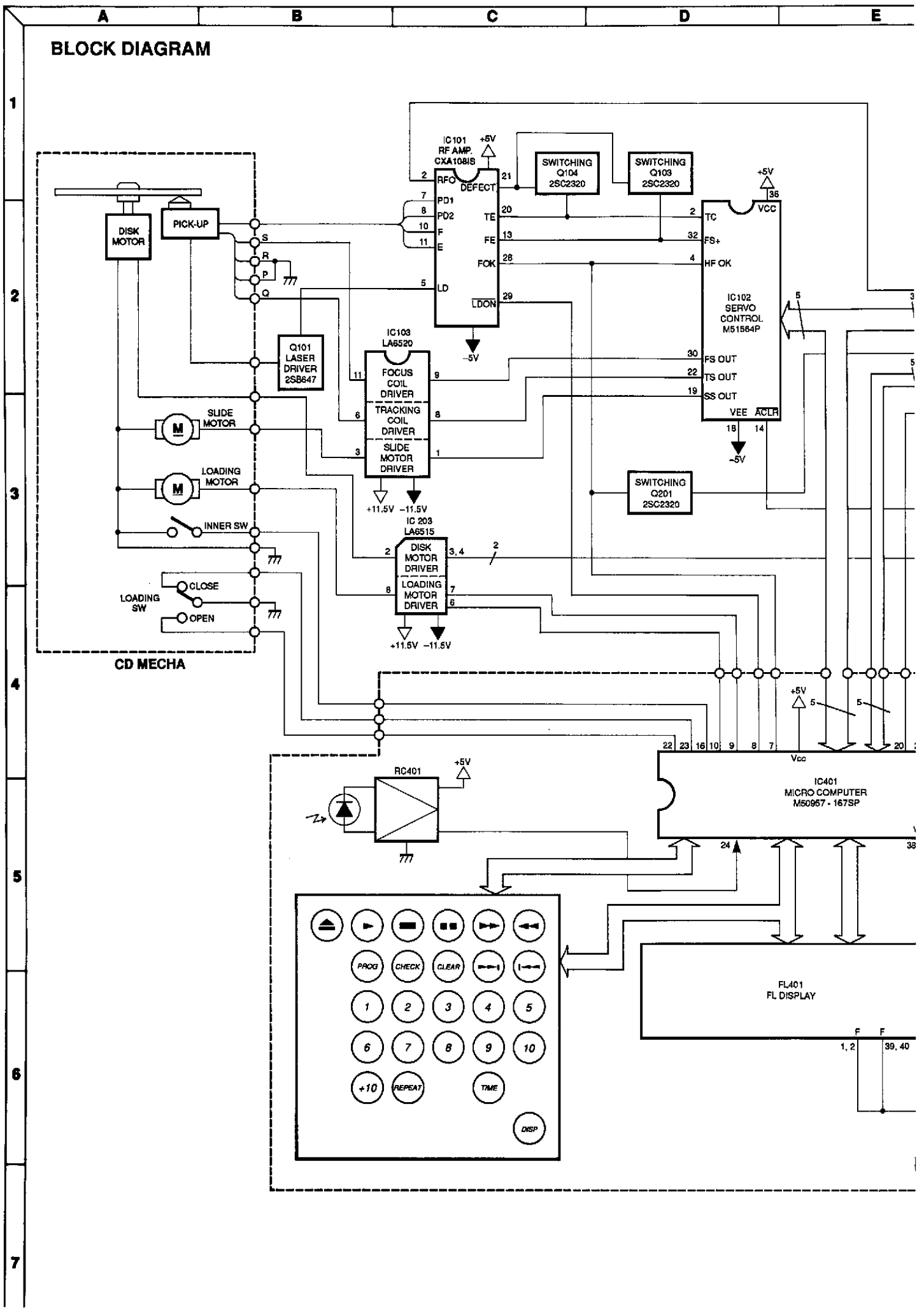

F

G

H

I

J

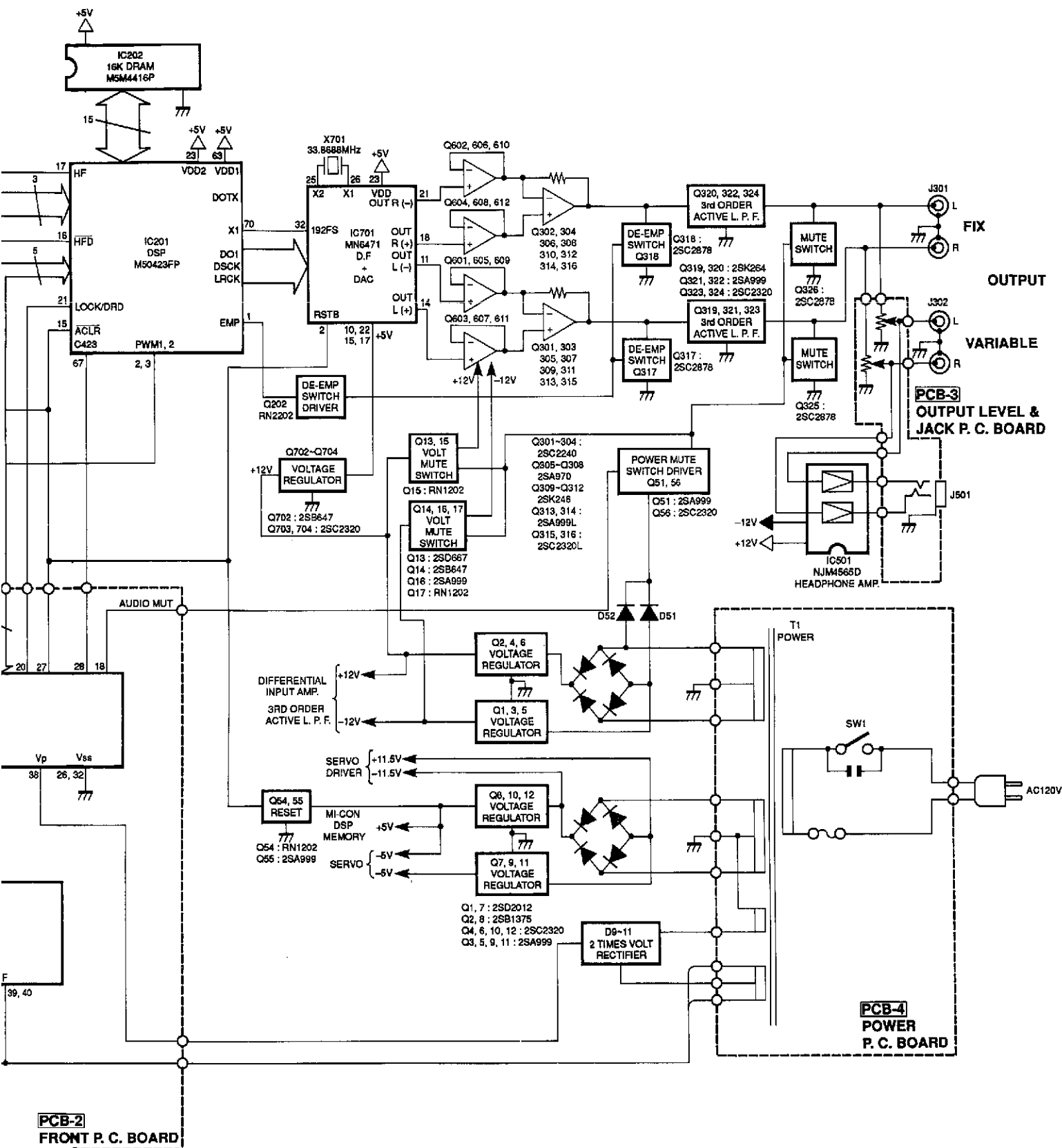

WIRING DIAGRAM

1
2
3
4
5
6
7

A B C D E

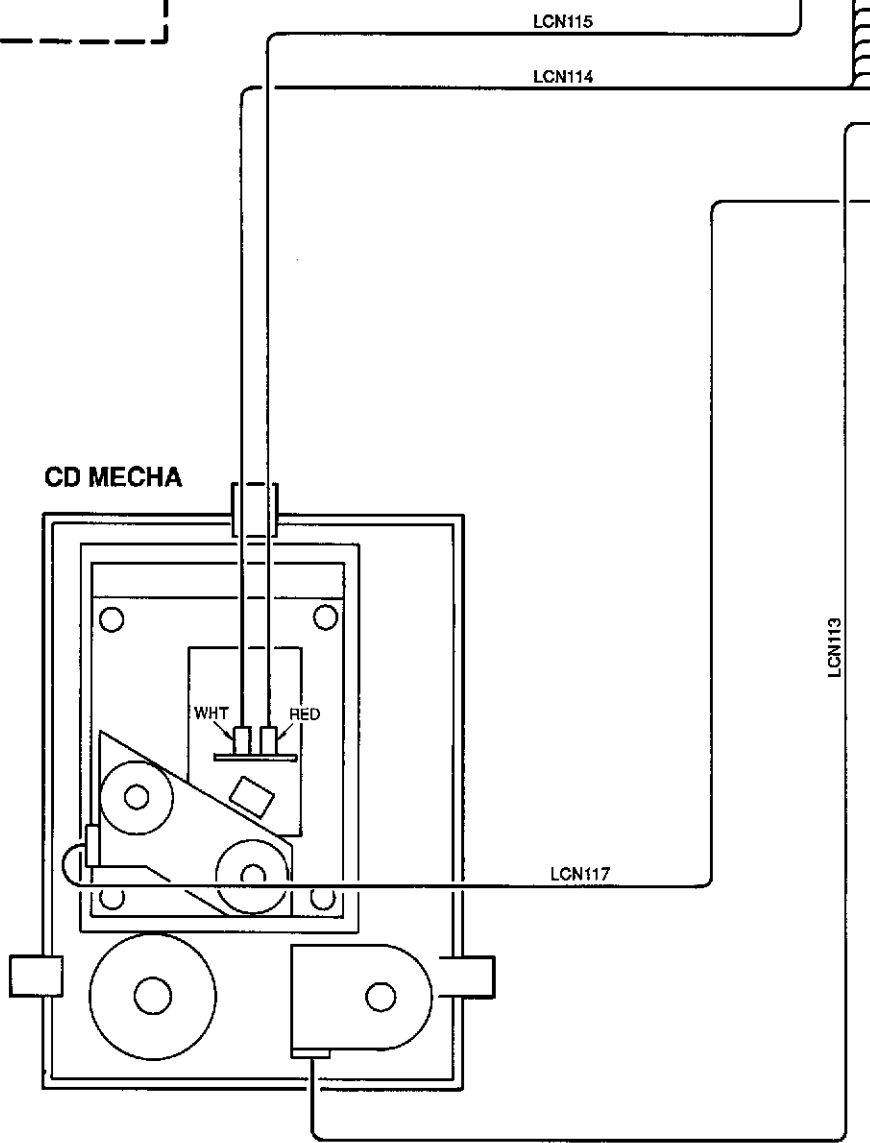
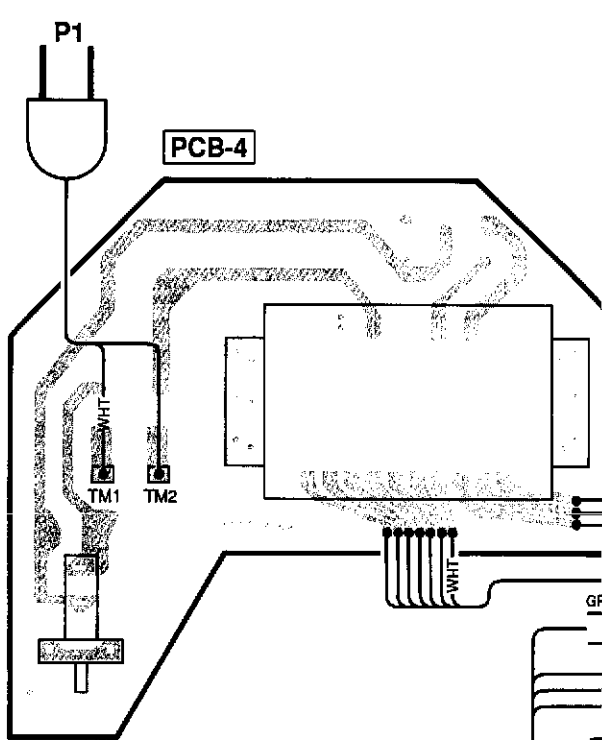
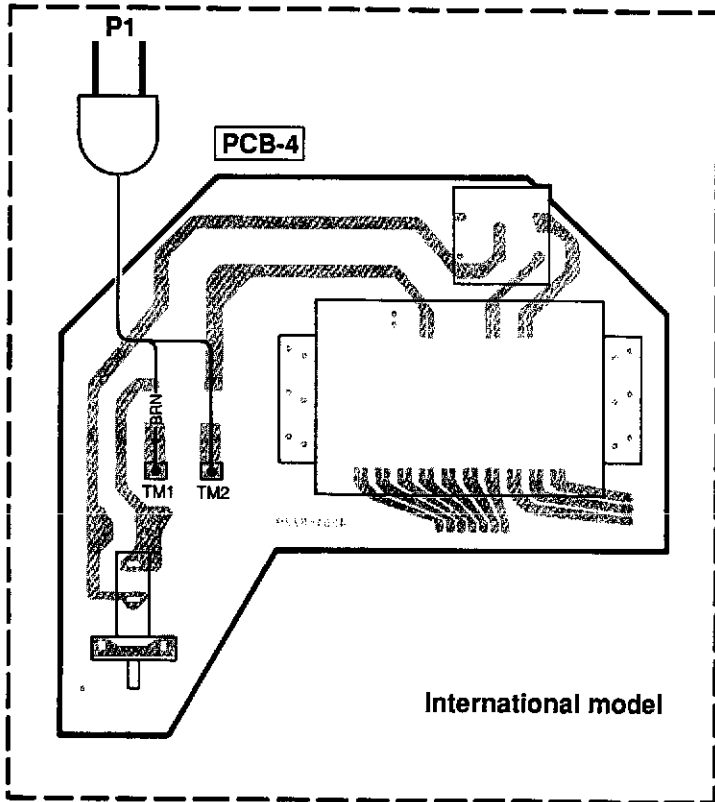

WIRE COLOR ABBREVIATIONS

RED : Red	YEL : Yellow
ORG : Orange	PUP : Purple
BLU : Blue	PIK : Pink
WHT : White	GRY : Gray
GRN : Green	BRN : Brown
BLK : Black	

PCB-1

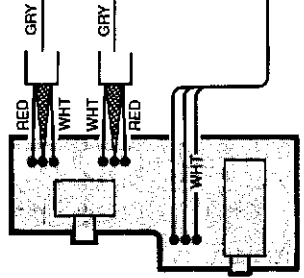
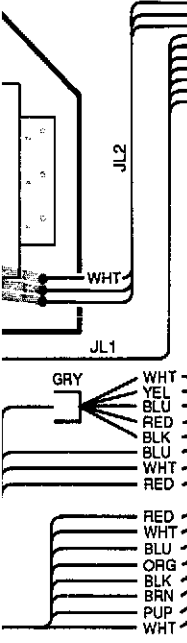
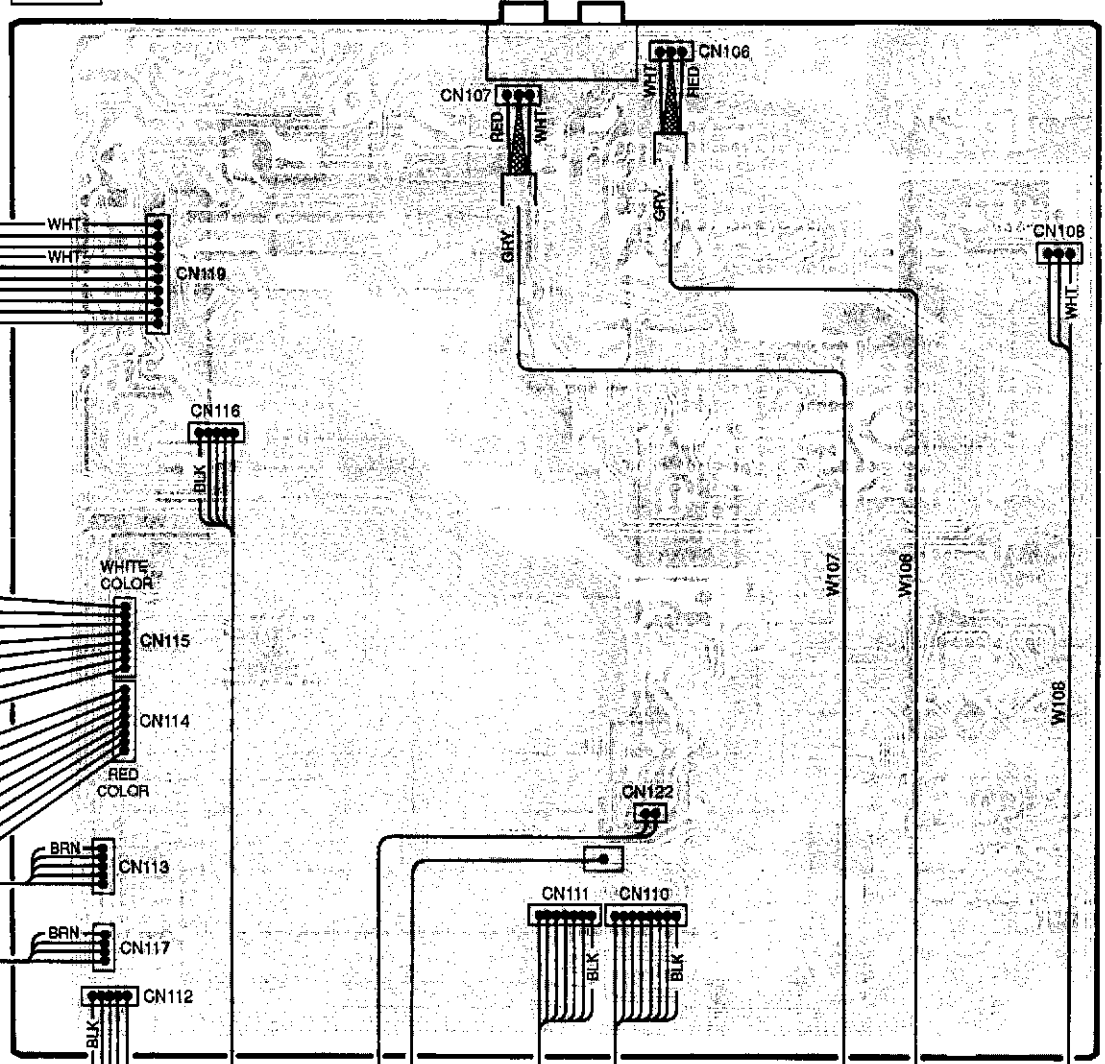

PCB-3

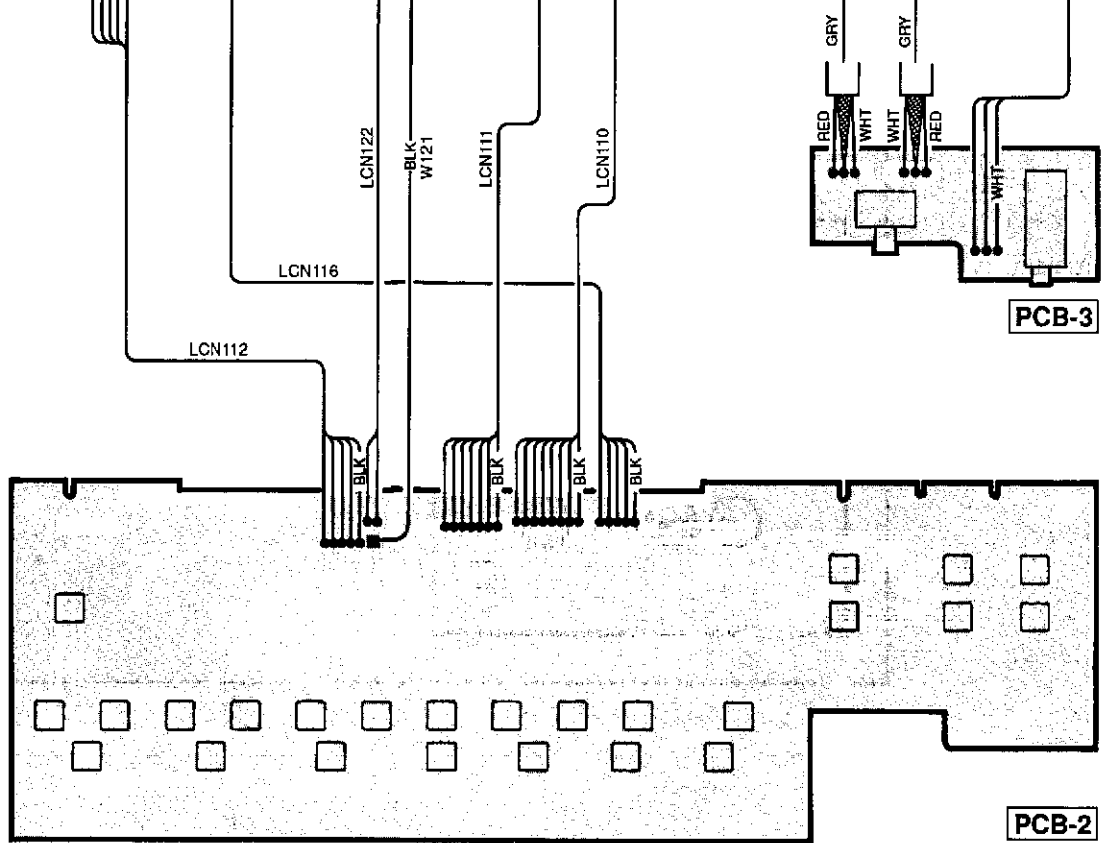

PCB-2

LCN113

PARTS LIST

Ser. No.	Ref. No.	Part No.	Description	Ser. No.	Ref. No.	Part No.	Description
PCB-1 MAIN P.C. BOARD							
CAPACITORS							
567	C2	5354-104593	CAP, MYL .1 μ	568	C211	5354-104593	CAP, MYL .1 μ
567	C3	5354-104593	CAP, MYL .1 μ	584	C212	5353-220534	CAP, MCA 22p
567	C4	5354-104593	CAP, MYL .1 μ	568	C213	5354-104593	CAP, MYL .1 μ
567	C5	5354-104593	CAP, MYL .1 μ	553	C214	5345-107D041	CAP, MINI ELE 100 μ 25V
567	C6	5354-104593	CAP, MYL .1 μ	553	C215	5345-107D041	CAP, MINI ELE 100 μ 25V
548	C7	5345-226F041	CAP, MINI ELE 22 μ 50V	586	C301	5353-181534	CAP, MCA 180p
544	C9	5345-477E041	CAP, MINI ELE 470 μ 35V	586	C302	5353-181534	CAP, MCA 180p
543	C10	5345-228D041	CAP, MINI ELE 2200 μ 25V	555	C303	5345-S06DM227	CAP, MINI ELE 220 μ 25V
543	C11	5345-228D041	CAP, MINI ELE 2200 μ 25V	555	C304	5345-S06DM227	CAP, MINI ELE 220 μ 25V
546	C12	5345-477C041	CAP, MINI ELE 470 μ 16V	572	C305	5359-2735851	CAP, PPP .027 μ
546	C13	5345-477C041	CAP, MINI ELE 470 μ 16V	572	C306	5359-2735851	CAP, PPP .027 μ
545	C14	5345-108C041	CAP, MINI ELE 1000 μ 16V	573	C307	5359-3915851	CAP, PPP 390p
545	C15	5345-108C041	CAP, MINI ELE 1000 μ 16V	573	C308	5359-3915851	CAP, PPP 390p
541	C16	5345-228C041	CAP, MINI ELE 2200 μ 16V	573	C309	5359-3915851	CAP, PPP 390p
541	C17	5345-228C041	CAP, MINI ELE 2200 μ 16V	573	C310	5359-3915851	CAP, PPP 390p
547	C18	5345-227B041	CAP, MINI ELE 220 μ 10V	574	C311	5359-1525851	CAP, PPP 1500p
547	C19	5345-227B041	CAP, MINI ELE 220 μ 10V	574	C312	5359-1525851	CAP, PPP 1500p
545	C20	5345-108C041	CAP, MINI ELE 1000 μ 16V	561	C313	5345-S06BM107	CAP, MINI ELE 100 μ 10V
545	C21	5345-108C041	CAP, MINI ELE 1000 μ 16V	561	C314	5345-S06BM107	CAP, MINI ELE 100 μ 10V
556	C22	5345-106F041	CAP, MINI ELE 10 μ 50V	561	C315	5345-S06BM107	CAP, MINI ELE 100 μ 10V
550	C51	5345-226D041	CAP, MINI ELE 22 μ 25V	561	C316	5345-S06BM107	CAP, MINI ELE 100 μ 10V
550	C52	5345-226D041	CAP, MINI ELE 22 μ 25V	587	C317	5353-050534	CAP, MCA 5p
549	C53	5345-107B041	CAP, MINI ELE 100 μ 10V	587	C318	5353-050534	CAP, MCA 5p
551	C54	5345-106F041	CAP, MINI ELE 10 μ 50V	590	C319	5345-S06DM227	CAP, MINI ELE 220 μ 25V
551	C55	5345-106F041	CAP, MINI ELE 10 μ 50V	590	C320	5345-S06DM227	CAP, MINI ELE 220 μ 25V
577	C56	5359-1035851	CAP, PPP .01 μ	559	C501	5345-478D041	CAP, MINI ELE 47 μ 25V
542	C57	5345-108D041	CAP, MINI ELE 1000 μ 25V	559	C502	5345-478D041	CAP, MINI ELE 47 μ 25V
552	C58	5345-105F041	CAP, MINI ELE 1 μ 50V	584	C503	5353-220534	CAP, MCA 22p
549	C101	5345-107B041	CAP, MINI ELE 100 μ 10V	584	C504	5353-220534	CAP, MCA 22p
583	C102	5353-100534	CAP, MCA 10p	585	C601	5353-330534	CAP, MCA 33p
583	C103	5353-100534	CAP, MCA 10p	585	C602	5353-330534	CAP, MCA 33p
583	C104	5353-100534	CAP, MCA 10p	588	C603	5353-820534	CAP, MCA 82p
579	C105	5359-3325851	CAP, PPP 3300p	588	C604	5353-820534	CAP, MCA 82p
569	C106	5354-333593	CAP, MYL .033 μ	590	C605	5345-S06DM227	CAP, MINI ELE 220 μ 25V
569	C107	5354-333593	CAP, MYL .033 μ	590	C606	5345-S06DM227	CAP, MINI ELE 220 μ 25V
577	C108	5359-1035851	CAP, PPP .01 μ	562	C701	5345-S06FM106	CAP, MINI ELE 10 μ 50V
554	C109	5345-476B041	CAP, MINI ELE 47 μ 10V	562	C702	5345-S06FM106	CAP, MINI ELE 10 μ 50V
554	C110	5345-476B041	CAP, MINI ELE 47 μ 10V	562	C703	5345-S06FM106	CAP, MINI ELE 10 μ 50V
554	C111	5345-476B041	CAP, MINI ELE 47 μ 10V	562	C704	5345-S06FM106	CAP, MINI ELE 10 μ 50V
557	C112	5345-474F041	CAP, MINI ELE 47 μ 50V	562	C705	5345-S06FM106	CAP, MINI ELE 10 μ 50V
550	C113	5345-226D0951	CAP, MINI ELE 22 μ 25V	562	C706	5345-S06FM106	CAP, MINI ELE 10 μ 50V
570	C114	5354-683593	CAP, MYL .068 μ	587	C707	5353-050534	CAP, MCA 5p
580	C115	5359-6815851	CAP, PPP 680p	587	C708	5353-050534	CAP, MCA 5p
565	C116	5354-274593	CAP, MYL .27 μ	561	C709	5345-S06BM107	CAP, MINI ELE 100 μ 10V
560	C117	5342-105F041	CAP, ELE BP 1 μ 50V	547	C710	5345-227B041	CAP, MINI ELE 220 μ 10V
568	C118	5354-104593	CAP, MYL .1 μ	555	C711	5345-S06DM477	CAP, MINI ELE 470 μ 25V
581	C119	5359-4725851	CAP, PPP 4700p	RESISTORS			
577	C121	5359-1035851	CAP, PPP .01 μ	606	R3	5135-222522	RES, CBN 1/2P 2.2K
558	C122	5345-684F0951	CAP, MINI ELE 0.68 μ 50V	606	R4	5135-222522	RES, CBN 1/2P 2.2K
576	C123	5359-3925851	CAP, PPP 3900p	598	R5	5135-471522	RES, CBN 1/2P 470
575	C124	5359-1515851	CAP, PPP 150p	598	R6	5135-471522	RES, CBN 1/2P 470
556	C125	5345-106F041	CAP, MINI ELE 10 μ 50V	611	R7	5135-101522	RES, CBN 1/2P 100
557	C126	5345-474F041	CAP, MINI ELE 47 μ 50V	611	R8	5135-101522	RES, CBN 1/2P 100
564	C127	5354-563593	CAP, MYL .056 μ	620	R9	5135-4R7522	RES, CBN 1/2P 4.7
554	C128	5345-476B041	CAP, MINI ELE 47 μ 10V	620	R10	5135-4R7522	RES, CBN 1/2P 4.7
554	C129	5345-476B041	CAP, MINI ELE 47 μ 10V	618	R13	5135-152522	RES, CBN 1/2P 1.5K
568	C130	5354-104593	CAP, MYL .1 μ	618	R14	5135-152522	RES, CBN 1/2P 1.5K
568	C131	5354-104593	CAP, MYL .1 μ	598	R15	5135-471522	RES, CBN 1/2P 470
568	C132	5354-104593	CAP, MYL .1 μ	598	R16	5135-471522	RES, CBN 1/2P 470
553	C133	5345-107D041	CAP, MINI ELE 100 μ 25V	611	R17	5135-101522	RES, CBN 1/2P 100
553	C134	5345-107D041	CAP, MINI ELE 100 μ 25V	611	R18	5135-101522	RES, CBN 1/2P 100
579	C201	5359-3325851	CAP, PPP 3300p	619	R19	5135-2R2522	RES, CBN 1/2P 2.2
576	C202	5359-5625851	CAP, PPP 5600p	619	R20	5135-2R2522	RES, CBN 1/2P 2.2
578	C203	5359-4715851	CAP, PPP 470p	592	R21	5135-103522	RES, CBN 1/2P 10K
566	C204	5354-154593	CAP, MYL .15 μ	592	R22	5135-103522	RES, CBN 1/2P 10K
561	C206	5345-S06BM107	CAP, MINI ELE 100 μ 10V	617	R23	5135-473522	RES, CBN 1/2P 47K
563	C207	5345-106F0951	CAP, MINI ELE 10 μ 50V	594	R24	5135-223522	RES, CBN 1/2P 22K
578	C209	5359-4715851	CAP, PPP 470p	592	R25	5135-103522	RES, CBN 1/2P 10K
578	C210	5359-4715851	CAP, PPP 470p	593	R26	5135-102522	RES, CBN 1/2P 1K
				594	R29	5135-223522	RES, CBN 1/2P 22K
				611	R30	5135-101522	RES, CBN 1/2P 100
				611	R31	5135-101522	RES, CBN 1/2P 100

Ser. No.	Ref. No.	Part No.	Description
599	R51	5135-152522	RES, CBN 1/2P 1.5K
600	R52	5135-224522	RES, CBN 1/2P 220K
594	R53	5135-223522	RES, CBN 1/2P 22K
592	R54	5135-103522	RES, CBN 1/2P 10K
597	R55	5135-101522	RES, CBN 1/2P 100
598	R56	5135-471522	RES, CBN 1/2P 470
602	R59	5135-104522	RES, CBN 1/2P 100K
602	R60	5135-104522	RES, CBN 1/2P 100K
655	R61	5232-103J16P	RES, CBN 1/6P 10K
601	R65	5135-272522	RES, CBN 1/2P 2.7K
623	R66	5135-221522	RES, CBN 1/2P 220
595	R101	5135-220522	RES, CBN 1/2P 22
661	R102	5232-222J16P	RES, CBN 1/6P 2.2K
663	R103	5232-163J16P	RES, CBN 1/6P 16K
662	R104	5232-822J16P	RES, CBN 1/6P 8.2K
664	R105	5232-223J16P	RES, CBN 1/6P 22K
593	R106	5135-102522	RES, CBN 1/2P 1K
596	R107	5135-910522	RES, CBN 1/2P 91
665	R108	5232-183J16P	RES, CBN 1/6P 18K
665	R109	5232-153J16P	RES, CBN 1/6P 15K
593	R110	5135-102522	RES, CBN 1/2P 1K
591	R111	5135-103522	RES, CBN 1/2P 10K
653	R112	5232-104J16P	RES, CBN 1/6P 100K
666	R113	5232-273J16P	RES, CBN 1/6P 27K
594	R114	5135-223522	RES, CBN 1/2P 22K
673	R115	5232-683J16P	RES, CBN 1/6P 68K
659	R116	5232-153J16P	RES, CBN 1/6P 15K
672	R117	5232-682J16P	RES, CBN 1/6P 6.8K
652	R118	5232-221J16P	RES, CBN 1/6P 220
667	R119	5232-473J16P	RES, CBN 1/6P 47K
591	R120	5135-103522	RES, CBN 1/2P 10K
591	R121	5135-103522	RES, CBN 1/2P 10K
666	R122	5232-273J16P	RES, CBN 1/6P 27K
591	R124	5135-103522	RES, CBN 1/2P 10K
656	R125	5232-102J16P	RES, CBN 1/6P 1K
653	R126	5232-104J16P	RES, CBN 1/6P 100K
654	R127	5232-104J16P	RES, CBN 1/6P 100K
667	R128	5232-473J16P	RES, CBN 1/6P 47K
655	R129	5232-103J16P	RES, CBN 1/6P 10K
671	R130	5232-822J16P	RES, CBN 1/6P 8.2K
654	R131	5232-104J16P	RES, CBN 1/6P 100K
654	R132	5232-104J16P	RES, CBN 1/6P 100K
670	R133	5232-562J16P	RES, CBN 1/6P 5.6K
668	R134	5232-332J16P	RES, CBN 1/6P 3.3K
655	R135	5232-153J16P	RES, CBN 1/6P 15K
660	R136	5232-333J16P	RES, CBN 1/6P 33K
660	R137	5232-393J16P	RES, CBN 1/6P 39K
664	R138	5232-223J16P	RES, CBN 1/6P 22K
674	R139	5232-472J16P	RES, CBN 1/6P 4.7K
669	R140	5232-393J16P	RES, CBN 1/6P 39K
651	R141	5232-100J16P	RES, CBN 1/6P 10
651	R142	5232-100J16P	RES, CBN 1/6P 10
651	R143	5232-100J16P	RES, CBN 1/6P 10
622	R150	5135-4R7522	RES, CBN 1/2P 4.7
622	R151	5135-4R7522	RES, CBN 1/2P 4.7
622	R152	5135-4R7522	RES, CBN 1/2P 4.7
622	R153	5135-4R7522	RES, CBN 1/2P 4.7
681	⚠ R154	5102-4R75116	RES, FUSE 4.7
681	⚠ R155	5102-4R75116	RES, FUSE 4.7
664	R201	5232-223J16P	RES, CBN 1/6P 22K
661	R202	5232-222J16P	RES, CBN 1/6P 2.2K
675	R203	5232-124J16P	RES, CBN 1/6P 120K
655	R204	5232-103J16P	RES, CBN 1/6P 10K
654	R205	5232-104J16P	RES, CBN 1/6P 100K
594	R207	5135-223522	RES, CBN 1/2P 22K
653	R209	5232-104J16P	RES, CBN 1/6P 100K
653	R210	5232-104J16P	RES, CBN 1/6P 100K
657	R211	5232-474J16P	RES, CBN 1/6P 470K
657	R212	5232-474J16P	RES, CBN 1/6P 470K
651	R213	5232-100J16P	RES, CBN 1/6P 10
653	R214	5232-104J16P	RES, CBN 1/6P 100K
653	R215	5232-104J16P	RES, CBN 1/6P 100K
654	R216	5232-104J16P	RES, CBN 1/6P 100K
653	R217	5232-104J16P	RES, CBN 1/6P 100K

Ser. No.	Ref. No.	Part No.	Description
651	R218	5232-100J16P	RES, CBN 1/6P 10
598	R219	5135-471522	RES, CBN 1/2P 470
681	⚠ R220	5102-4R75116	RES, FUSE 4.7
681	⚠ R221	5102-4R75116	RES, FUSE 4.7
681	⚠ R222	5102-4R75116	RES, FUSE 4.7
676	R223	5232-225J16P	RES, CBN 1/6P 2.2M
606	R224	5135-222522	RES, CBN 1/2P 2.2K
606	R225	5135-222522	RES, CBN 1/2P 2.2K
606	R226	5135-222522	RES, CBN 1/2P 2.2K
606	R227	5135-222522	RES, CBN 1/2P 2.2K
606	R228	5135-222522	RES, CBN 1/2P 2.2K
606	R229	5135-222522	RES, CBN 1/2P 2.2K
688	R250	5212-103J0701	PACK RESISTOR 10Kx7
687	R251	5212-103J0301	PACK RESISTOR 10Kx3
597	R301	5135-101522	RES, CBN 1/2P 100
597	R302	5135-101522	RES, CBN 1/2P 100
597	R303	5135-101522	RES, CBN 1/2P 100
597	R304	5135-101522	RES, CBN 1/2P 100
597	R305	5135-101522	RES, CBN 1/2P 100
597	R306	5135-101522	RES, CBN 1/2P 100
597	R307	5135-101522	RES, CBN 1/2P 100
597	R308	5135-101522	RES, CBN 1/2P 100
605	R309	5135-470522	RES, CBN 1/2P 47
605	R310	5135-470522	RES, CBN 1/2P 47
605	R311	5135-470522	RES, CBN 1/2P 47
605	R312	5135-470522	RES, CBN 1/2P 47
607	R313	5135-121522	RES, CBN 1/2P 120
607	R314	5135-121522	RES, CBN 1/2P 120
607	R315	5135-121522	RES, CBN 1/2P 120
607	R316	5135-121522	RES, CBN 1/2P 120
603	R317	5135-471522	RES, CBN 1/2P 470
603	R318	5135-471522	RES, CBN 1/2P 470
603	R319	5135-471522	RES, CBN 1/2P 470
603	R320	5135-471522	RES, CBN 1/2P 470
603	R321	5135-471522	RES, CBN 1/2P 470
603	R322	5135-471522	RES, CBN 1/2P 470
603	R323	5135-471522	RES, CBN 1/2P 470
603	R324	5135-471522	RES, CBN 1/2P 470
606	R325	5135-222522	RES, CBN 1/2P 2.2K
606	R326	5135-222522	RES, CBN 1/2P 2.2K
592	R327	5135-103522	RES, CBN 1/2P 10K
592	R328	5135-103522	RES, CBN 1/2P 10K
606	R329	5135-222522	RES, CBN 1/2P 2.2K
606	R330	5135-222522	RES, CBN 1/2P 2.2K
608	R331	5135-122522	RES, CBN 1/2P 1.2K
608	R332	5135-122522	RES, CBN 1/2P 1.2K
612	R333	5135-561522	RES, CBN 1/2P 560
612	R334	5135-561522	RES, CBN 1/2P 560
613	R335	5135-105522	RES, CBN 1/2P 1M
613	R336	5135-105522	RES, CBN 1/2P 1M
609	R337	5135-152522	RES, CBN 1/2P 1.5K
609	R338	5135-152522	RES, CBN 1/2P 1.5K
610	R339	5135-472522	RES, CBN 1/2P 4.7K
610	R340	5135-472522	RES, CBN 1/2P 4.7K
604	R341	5135-472522	RES, CBN 1/2P 4.7K
604	R342	5135-472522	RES, CBN 1/2P 4.7K
611	R343	5135-101522	RES, CBN 1/2P 100
611	R344	5135-101522	RES, CBN 1/2P 100
593	R345	5135-102522	RES, CBN 1/2P 1K
593	R346	5135-102522	RES, CBN 1/2P 1K
611	R347	5135-101522	RES, CBN 1/2P 100
611	R348	5135-101522	RES, CBN 1/2P 100
611	R349	5135-101522	RES, CBN 1/2P 100
611	R350	5135-101522	RES, CBN 1/2P 100
595	R351	5135-220522	RES, CBN 1/2P 22
595	R352	5135-220522	RES, CBN 1/2P 22
615	R353	5135-182522	RES, CBN 1/2P 1.8K
615	R354	5135-182522	RES, CBN 1/2P 1.8K
616	R355	5135-154522	RES, CBN 1/2P 150K
616	R356	5135-154522	RES, CBN 1/2P 150K
591	R357	5135-103522	RES, CBN 1/2P 10K
591	R358	5135-103522	RES, CBN 1/2P 10K
614	R359	5135-472522	RES, CBN 1/2P 4.7K
614	R360	5135-472522	RES, CBN 1/2P 4.7K

Ser. No.	Ref. No.	Part No.	Description	Ser. No.	Ref. No.	Part No.	Description
595	R361	5135-220522	RES, CBN 1/2P 22	514	Q103	5613-2320(F)	XISTOR, NPN R
595	R362	5135-220522	RES, CBN 1/2P 22	514	Q104	5613-2320(F)	XISTOR, NPN R
655	R501	5232-103J16P	RES, CBN 1/6P 10K	513	Q201	5613-2320(F)	XISTOR, NPN R
655	R502	5232-103J16P	RES, CBN 1/6P 10K	517	Q202	5611-RN2202	XISTOR, PNP R
660	R503	5232-333J16P	RES, CBN 1/6P 33K	519	Q301	5613-2240(BL)	XISTOR, NPN R
660	R504	5232-333J16P	RES, CBN 1/6P 33K	519	Q302	5613-2240(BL)	XISTOR, NPN R
659	R505	5232-153J16P	RES, CBN 1/6P 15K	519	Q303	5613-2240(BL)	XISTOR, NPN R
659	R506	5232-153J16P	RES, CBN 1/6P 15K	519	Q304	5613-2240(BL)	XISTOR, NPN R
658	R507	5232-101J16P	RES, CBN 1/6P 100	520	Q305	5611-970(BL)	XISTOR, PNP R
658	R508	5232-101J16P	RES, CBN 1/6P 100	520	Q306	5611-970(BL)	XISTOR, PNP R
621	R509	5135-100522	RES, CBN 1/2P 10	520	Q307	5611-970(BL)	XISTOR, PNP R
621	R510	5135-100522	RES, CBN 1/2P 10	520	Q308	5611-970(BL)	XISTOR, PNP R
591	R601	5135-103522	RES, CBN 1/2P 10K	522	Q309	5616-SK246GR2	FET, N-CH
591	R602	5135-103522	RES, CBN 1/2P 10K	522	Q310	5616-SK246GR2	FET, N-CH
591	R603	5135-103522	RES, CBN 1/2P 10K	522	Q311	5616-SK246GR2	FET, N-CH
591	R604	5135-103522	RES, CBN 1/2P 10K	522	Q312	5616-SK246GR2	FET, N-CH
593	R605	5135-102522	RES, CBN 1/2P 1K	515	Q313	5611-999L(F)	XISTOR, PNP R
593	R606	5135-102522	RES, CBN 1/2P 1K	515	Q314	5611-999L(F)	XISTOR, PNP R
593	R607	5135-102522	RES, CBN 1/2P 1K	514	Q315	5613-2320L(F)	XISTOR, NPN R
593	R608	5135-102522	RES, CBN 1/2P 1K	514	Q316	5613-2320L(F)	XISTOR, NPN R
597	R609	5135-101522	RES, CBN 1/2P 100	521	Q317	5613-2878(B)	XISTOR, NPN R
597	R610	5135-101522	RES, CBN 1/2P 100	521	Q318	5613-2878(B)	XISTOR, NPN R
597	R611	5135-101522	RES, CBN 1/2P 100	522	Q319	5616-SK246GR2	FET, N-CH
597	R612	5135-101522	RES, CBN 1/2P 100	522	Q320	5616-SK246GR2	FET, N-CH
604	R617	5135-562522	RES, CBN 1/2P 5.6K	516	Q321	5611-999L(F)	XISTOR, PNP R
604	R618	5135-562522	RES, CBN 1/2P 5.6K	516	Q322	5611-999L(F)	XISTOR, PNP R
604	R619	5135-562522	RES, CBN 1/2P 5.6K	514	Q323	5613-2320L(F)	XISTOR, NPN R
604	R620	5135-562522	RES, CBN 1/2P 5.6K	514	Q324	5613-2320L(F)	XISTOR, NPN R
592	R621	5135-103522	RES, CBN 1/2P 10K	521	Q325	5613-2878(B)	XISTOR, NPN R
592	R622	5135-103522	RES, CBN 1/2P 10K	521	Q326	5613-2878(B)	XISTOR, NPN R
592	R623	5135-103522	RES, CBN 1/2P 10K	522	Q601	5616-SK246GR2	FET, N-CH
592	R624	5135-103522	RES, CBN 1/2P 10K	522	Q602	5616-SK246GR2	FET, N-CH
674	R701	5232-472J16P	RES, CBN 1/6P 4.7K	522	Q603	5616-SK246GR2	FET, N-CH
598	R702	5135-471522	RES, CBN 1/2P 470	522	Q604	5616-SK246GR2	FET, N-CH
598	R703	5135-471522	RES, CBN 1/2P 470	515	Q605	5611-999L(F)	XISTOR, PNP R
606	R704	5135-222522	RES, CBN 1/2P 2.2K	515	Q606	5611-999L(F)	XISTOR, PNP R
621	R705	5135-100522	RES, CBN 1/2P 10	515	Q607	5611-999L(F)	XISTOR, PNP R
611	R706	5135-101522	RES, CBN 1/2P 100	515	Q608	5611-999L(F)	XISTOR, PNP R
682	⚠ R707	5102-1005116	RES, FUSE 10	513	Q609	5613-2320L(F)	XISTOR, NPN R
682	⚠ R708	5102-1005116	RES, FUSE 10	513	Q610	5613-2320L(F)	XISTOR, NPN R
				513	Q611	5613-2320L(F)	XISTOR, NPN R
				513	Q612	5613-2320L(F)	XISTOR, NPN R
				511	Q702	5612-647(C)	XISTOR, PNP A
				513	Q703	5613-2320(F)	XISTOR, NPN R
				513	Q704	5613-2320(F)	XISTOR, NPN R
INTEGRATED CIRCUITS							
505	IC101	5653-CXA1081S	IC, LINEAR				
502	IC102	5654-M51564P	IC, DIGITAL				
506	IC103	5653-LA6520	IC, LINEAR				
501	IC201	5654-M50423FP	IC, DIGITAL				
504	IC202	5654-M5M4416P	IC, DIGITAL				
507	IC203	5653-LA6515	IC, LINEAR				
508	IC501	5653-NJM4565D	IC, LINEAR				
503	IC701	5654-MN6471M	IC, DIGITAL				
TRANSISTORS							
510	Q1	5614-2012	XISTOR, NPN A				
509	Q2	5612-1375	XISTOR, PNP A				
515	Q3	5611-999(F)	XISTOR, PNP R				
513	Q4	5613-2320(F)	XISTOR, NPN R				
515	Q5	5611-999(F)	XISTOR, PNP R				
513	Q6	5613-2320(F)	XISTOR, NPN R				
510	Q7	5614-2012	XISTOR, NPN A				
509	Q8	5612-1375	XISTOR, PNP A				
515	Q9	5611-999(F)	XISTOR, PNP R				
513	Q10	5613-2320(F)	XISTOR, NPN R				
515	Q11	5611-999(F)	XISTOR, PNP R				
513	Q12	5613-2320(F)	XISTOR, NPN R				
512	Q13	5614-667(C)	XISTOR, NPN A				
511	Q14	5612-647(C)	XISTOR, PNP A				
518	Q15	5613-RN1202	XISTOR, NPN R				
515	Q16	5611-999(F)	XISTOR, PNP R				
518	Q17	5613-RN1202	XISTOR, NPN R				
515	Q51	5611-999(F)	XISTOR, PNP R				
515	Q54	5611-999(F)	XISTOR, PNP R				
518	Q55	5613-RN1202	XISTOR, NPN R				
514	Q56	5613-2320(F)	XISTOR, NPN R				
511	Q101	5612-647(C)	XISTOR, PNP A				
				531	⚠ D1	5632-GP10E	DIODE, RECT
				531	⚠ D2	5632-GP10E	DIODE, RECT
				531	⚠ D3	5632-GP10E	DIODE, RECT
				531	⚠ D4	5632-GP10E	DIODE, RECT
				531	⚠ D5	5632-GP10E	DIODE, RECT
				531	⚠ D6	5632-GP10E	DIODE, RECT
				531	⚠ D7	5632-GP10E	DIODE, RECT
				531	⚠ D8	5632-GP10E	DIODE, RECT
				531	⚠ D9	5632-GP10E	DIODE, RECT
				531	⚠ D10	5632-GP10E	DIODE, RECT
				538	D11	5635-HZ5B-2	DIODE, ZENER
				539	D12	5635-HZ27-2	DIODE, ZENER
				540	D13	5635-HZ12B2L	DIODE, ZENER
				540	D14	5635-HZ12B2L	DIODE, ZENER
				535	D15	5635-HZ6B2L	DIODE, ZENER
				535	D16	5635-HZ6B2L	DIODE, ZENER
				531	D17	5632-GP10E	DIODE, RECT
				531	⚠ D19	5632-GP10E	DIODE, RECT
				531	⚠ D20	5632-GP10E	DIODE, RECT
				532	D21	5632-1S2473	DIODE, RECT
				531	D51	5632-GP10E	DIODE, RECT
				531	D52	5632-GP10E	DIODE, RECT
				532	D53	5632-1S2473	DIODE, RECT
				537	D54	5635-HZ6A2L	DIODE, ZENER
				532	D55	5632-1S2473	DIODE, RECT
				531	D56	5632-GP10E	DIODE, RECT
				536	D57	5635-HZ9B2L	DIODE, ZENER

Ser. No.	Ref. No.	Part No.	Description
533	D103	5631-1SS133	DIODE, DET
534	D104	5635-HZ3B-2	DIODE, ZENER
534	D105	5635-HZ3B-2	DIODE, ZENER
531	D106	5632-GP10E	DIODE, RECT
535	D701	5635-HZ6B2L	DIODE, ZENER

CONTROLS

684	VR101	5101-22301934	RES, SEMI FIX 22K
683	VR102	5101-50201934	RES, SEMI FIX 5K

MISCELLANEOUS

695	CN106	4443-030185	CONNECTOR
695	CN107	4443-030185	CONNECTOR
695	CN108	4443-030185	CONNECTOR
689	CN110	4443-0601140	CONNECTOR
693	CN111	4443-0701140	CONNECTOR
691	CN112	4443-0501140	CONNECTOR
691	CN113	4443-0501140	CONNECTOR
690	CN114	4443-03901008	CONNECTOR
689	CN115	4443-0601140	CONNECTOR
691	CN116	4443-0501140	CONNECTOR
692	CN117	4443-0401140	CONNECTOR
694	CN119	4443-100185	CONNECTOR
696	CN122	4443-0201140	CONNECTOR
746	J301	4489-02601004	PIN JACK, 4P
697	W102	4242-R0103161	JUMPER LEAD
703	W701	4132-R0105101	CORD, 2C
704	W702	4132-R0105251	CORD, 2C
703	W801	4132-R0105101	CORD, 2C
686	X701	5691-S0901343	XTAL, OSC
753		4214-132	TERMINAL

PCB-2 FRONT P.C. BOARD

CAPACITORS

721	C401	5345-S06FM106	CAP, MINI ELE 10μ/50V
720	C402	5354-104593	CAP, MYL .1μ
721	C403	5345-S06FM106	CAP, MINI ELE 10μ/50V
722	C404	5345-S06BM107	CAP, MINI ELE 100μ/10V

RESISTORS

723	R401	5212-103J0401	PACK RESISTOR 10Kx4
726	R402	5135-102522	RES, CBN 1/2P 1K
727	R403	5135-101522	RES, CBN 1/2P 100
728	R404	5135-332522	RES, CBN 1/2P 3.3K

INTEGRATED CIRCUIT

711	IC401	5654-M957-167	IC, DIGITAL
-----	-------	---------------	-------------

DIODES

717	D401	5632-1S2473	DIODE, RECT
718	D402	5631-1SS133	DIODE, DET
718	D403	5631-1SS133	DIODE, DET
718	D404	5631-1SS133	DIODE, DET
718	D405	5631-1SS133	DIODE, DET
718	D406	5631-1SS133	DIODE, DET
718	D407	5631-1SS133	DIODE, DET
718	D408	5631-1SS133	DIODE, DET
717	D409	5632-1S2473	DIODE, RECT
717	D410	5632-1S2473	DIODE, RECT
717	D411	5632-1S2473	DIODE, RECT
717	D412	5632-1S2473	DIODE, RECT
718	D413	5631-1SS133	DIODE, DET
717	D414	5632-1S2473	DIODE, RECT

MISCELLANEOUS

713	FL401	5722-046	TUBE DISPLAY
730	LCN110	4163-S0108161	CONNECTOR W/W
731	LCN111	4163-S0107161	CONNECTOR W/W
732	LCN112	4163-S0105161	CONNECTOR W/W
733	LCN116	4163-S0105301	CONNECTOR W/W
734	LCN122	4163-S0102251	CONNECTOR W/W
724	RC401	6143-00801	RECEIVE UNIT

Ser. No.	Ref. No.	Part No.	Description
715	SW401	4437-00606	SWITCH, PUSH
715	SW402	4437-00606	SWITCH, PUSH
715	SW403	4437-00606	SWITCH, PUSH
714	SW404	4437-00610	SWITCH, PUSH
714	SW405	4437-00610	SWITCH, PUSH
714	SW406	4437-00610	SWITCH, PUSH
715	SW409	4437-00606	SWITCH, PUSH
715	SW410	4437-00606	SWITCH, PUSH
715	SW411	4437-00606	SWITCH, PUSH
715	SW412	4437-00606	SWITCH, PUSH
715	SW413	4437-00606	SWITCH, PUSH
715	SW414	4437-00606	SWITCH, PUSH
715	SW415	4437-00606	SWITCH, PUSH
715	SW416	4437-00606	SWITCH, PUSH
714	SW418	4437-00610	SWITCH, PUSH
714	SW423	4437-00610	SWITCH, PUSH
714	SW424	4437-00610	SWITCH, PUSH
714	SW425	4437-00610	SWITCH, PUSH
714	SW426	4437-00610	SWITCH, PUSH
714	SW427	4437-00610	SWITCH, PUSH
714	SW428	4437-00610	SWITCH, PUSH
714	SW429	4437-00610	SWITCH, PUSH
714	SW430	4437-00610	SWITCH, PUSH
714	SW431	4437-00610	SWITCH, PUSH
714	SW432	4437-00610	SWITCH, PUSH

PCB-3 OUTPUT LEVEL & JACK P.C. BOARD

CAPACITOR

626	C505	5354-104593	CAP, MYL .1μ
-----	------	-------------	--------------

CONTROLS

743	VR301/302	5113-S0202502	RES, V CBN 16 5K
-----	-----------	---------------	------------------

MISCELLANEOUS

744	J501	4451-51501	JACK, 1P
628	L501	5995-1R0J107	COIL W/CORE
628	L502	5995-1R0J107	COIL W/CORE
628	L503	5995-1R0J107	COIL W/CORE
755	W106	2240-Z031	HOLDER
755	W107	2240-Z031	HOLDER
745	W108	4242-R0203351	JUMPER LEAD

PCB-4 POWER SWITCH P.C. BOARD

CAPACITORS

749	C1	5352-S010M103	CAP, MTL .01μ UA BK NB
749B	C1	5352-1030958	CAP, MTL .01μ I IB BB

RESISTOR

022B	R1	5135-335J50P	RES, CBN 1/2P 3.3M I IB BB
------	----	--------------	----------------------------

MISCELLANEOUS

751	JL1	4242-R0407201	JUMPER LEAD
750	JL2	4242-R0403201	JUMPER LEAD
748	SW1	4431-A017191	SWITCH, PUSH
021B	SW2	4411-1047111	SWITCH, ROTARY I IB BB
741	T1	5584-S6301	XFORMER, POWER UA BK
741B	T1	5584-S6302	XFORMER, POWER I IB BB
741D	T1	5584-S6303	XFORMER, POWER NB
752	TM1	4214-122	TERMINAL
752	TM2	4214-122	TERMINAL

CHASSIS MISCELLANEOUS PARTS LIST

701	LCN113	4163-03212005	CONNECTOR W/W
700	LCN114	4163-03210008	CONNECTOR W/W
699	LCN115	4163-03211008	CONNECTOR W/W
702	LCN117	4163-03207004	CONNECTOR W/W
768	P1	4161-03601202	CORD W/PLUG UA BK

Ser. No.	Ref. No.	Part No.	Description
768B	△ P1	4161-03701220	CORD W/PLUG J 1B
768D	△ P1	4161-00401192	CORD W/PLUG NB
768E	△ P1	4161-04100	CORD W/PLUG 6B

Ser. No.	Ref. No.	Part No.	Description
768B	△ P1	4161-03701220	CORD W/PLUG J 1B
768D	△ P1	4161-00401192	CORD W/PLUG NB
768E	△ P1	4161-04100	CORD W/PLUG 6B

ABBREVIATIONS IN PARTS LIST

CAPACITORS

CAP, MINI ELE	: Electronic
CAP, CER	: Ceramic
CAP, PPP	: Polypropylene
CAP, MYL	: Mylar
CAP, MCA	: Mica
CAP, MINI BP	: Bipolar
CAP, ELE BP	: Electrolytic Bipolar
470μ	: 470μF
6800p	: 6800pF
.047μ	: 0.047μF

RESISTORS

RES, CBN 1/6P	: Carbon 1/6W
RES, FUSE	: Fuse
RES, CEM 5P	: Cement 5W
RES, MTL 1P	: Metal 1W
2.2k	: 2.2kΩ
220	: 220Ω

TRANSISTORS

XISTOR	: Transistor
FET	: Field Effect Transistor
CONTROLS	
RES, SEMI FIX	: Semi-fixed Resistor

NOTE



SAFETY RELATED COMPONENT. USE ONLY EXACT REPLACEMENT PART AS SPECIFIED.

INFRARED REMOTE CONTROL SCHEMATIC DIAGRAM

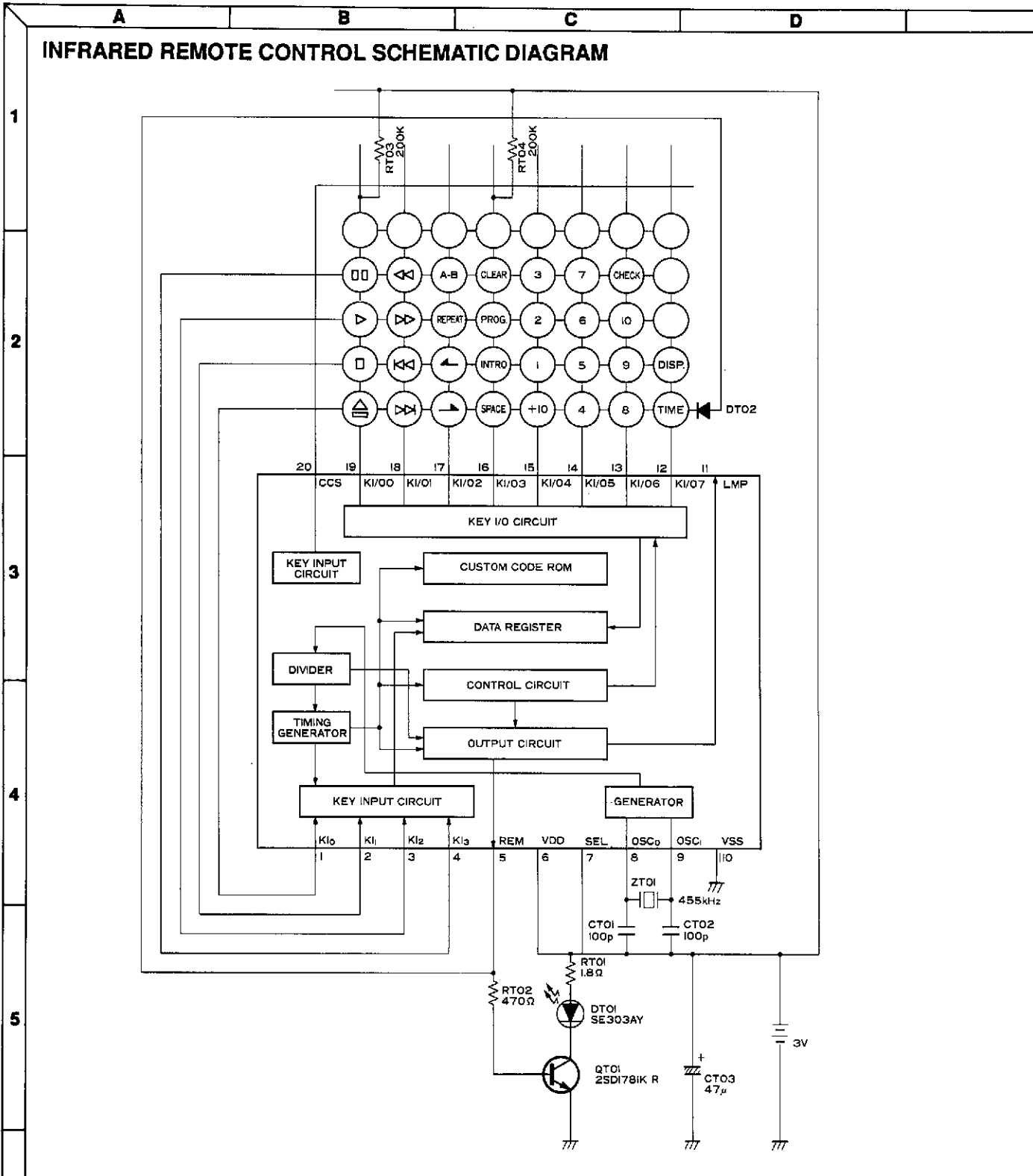

SCHEMATIC DIAGRAM

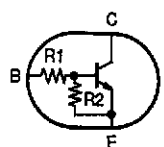
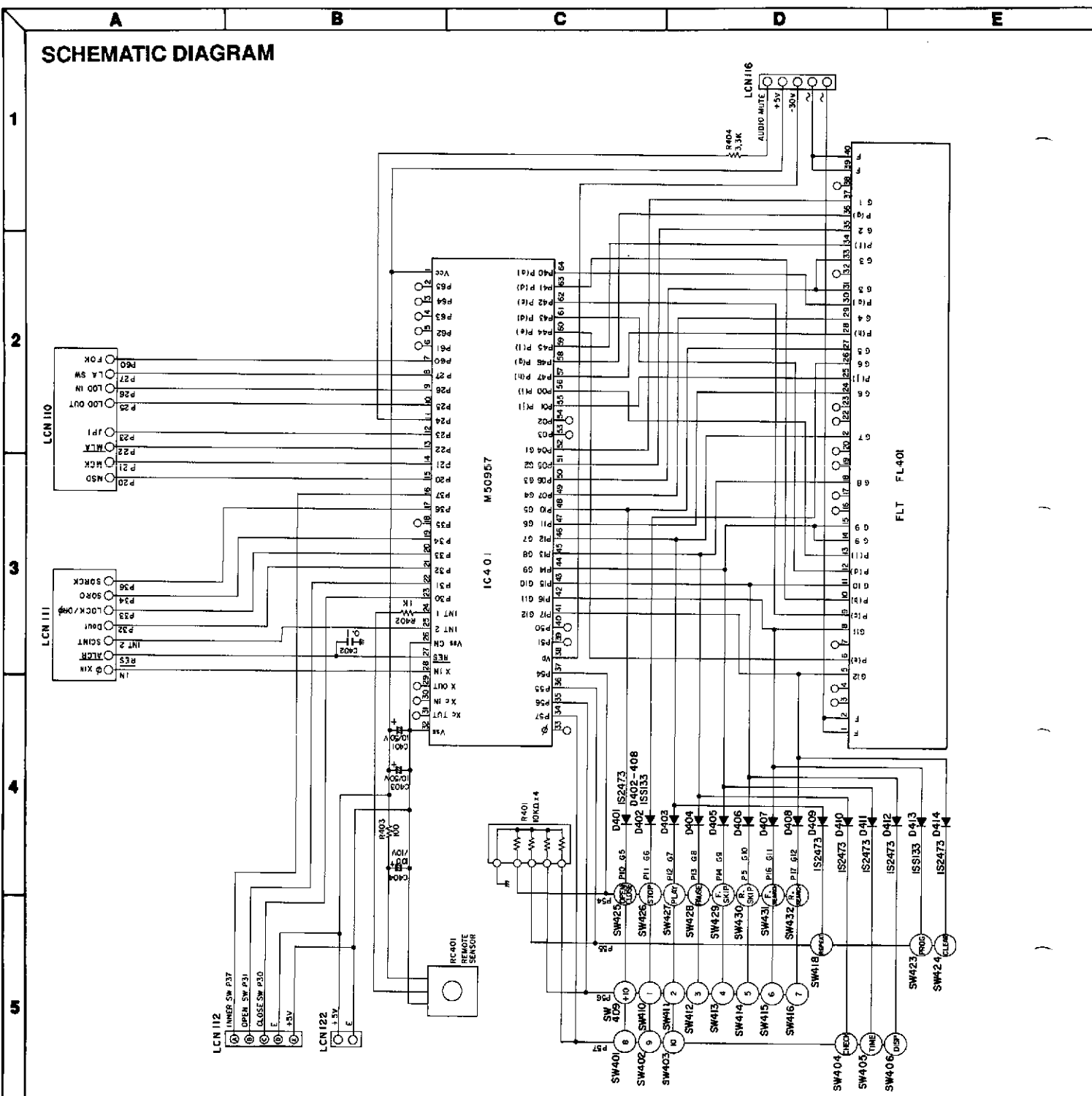

Type	R1(kΩ)	R2(kΩ)
RN1202	10	10

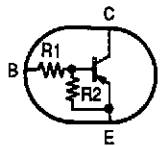

Type	R1(kΩ)	R2(kΩ)
RN2202	10	10

- NOTE:**
1. ALL RESISTANCES VALUES ARE IN Ω.
KΩ=1000Ω, MΩ=1000KΩ.
 2. ALL CAPACITANCES VALUE ARE IN μF UNLESS OTHERWISE NOTED. P=μμF.
 3. ... V : DC VOLTAGE AT PLAY MODE.
(... V): DC VOLTAGE AT STOP MODE.
 4. SAFETY REQUIREMENTS COMPONENTS IN ACCORDANCE WITH PRESENT SAFETY REGULATIONS, THESE COMPONENTS MUST ONLY BE REPLACED BY ORIGINAL PARTS.



A B C D E F G

SCHEMATIC DIAGRAM

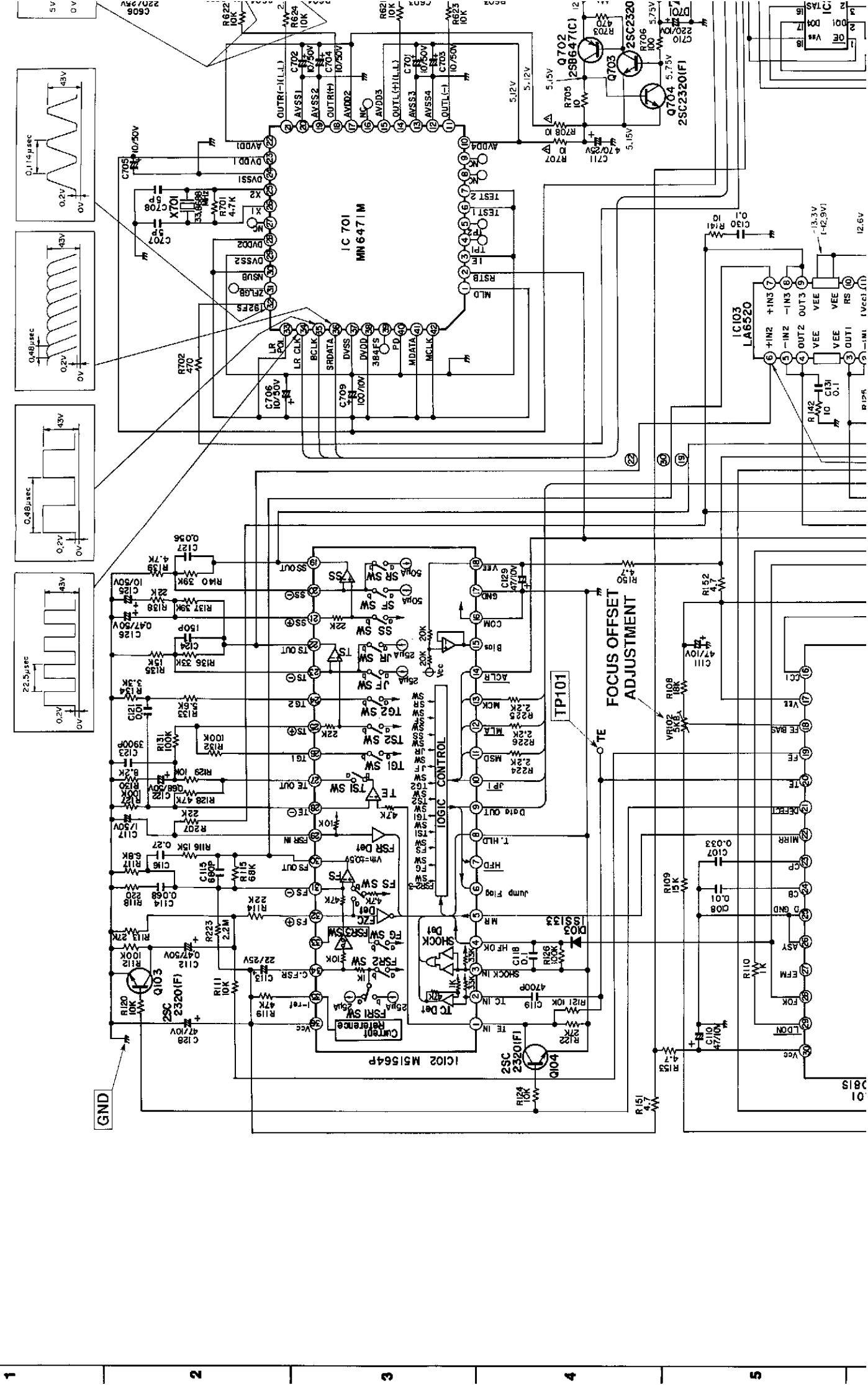

1 2 3 4 5

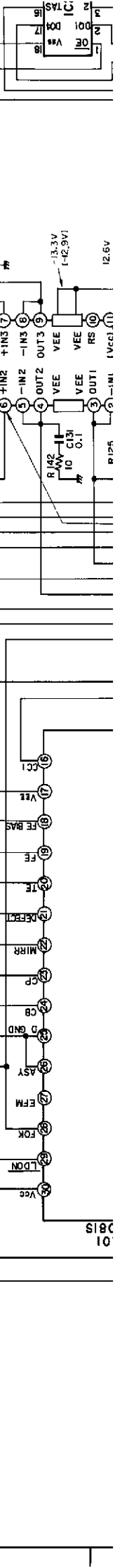

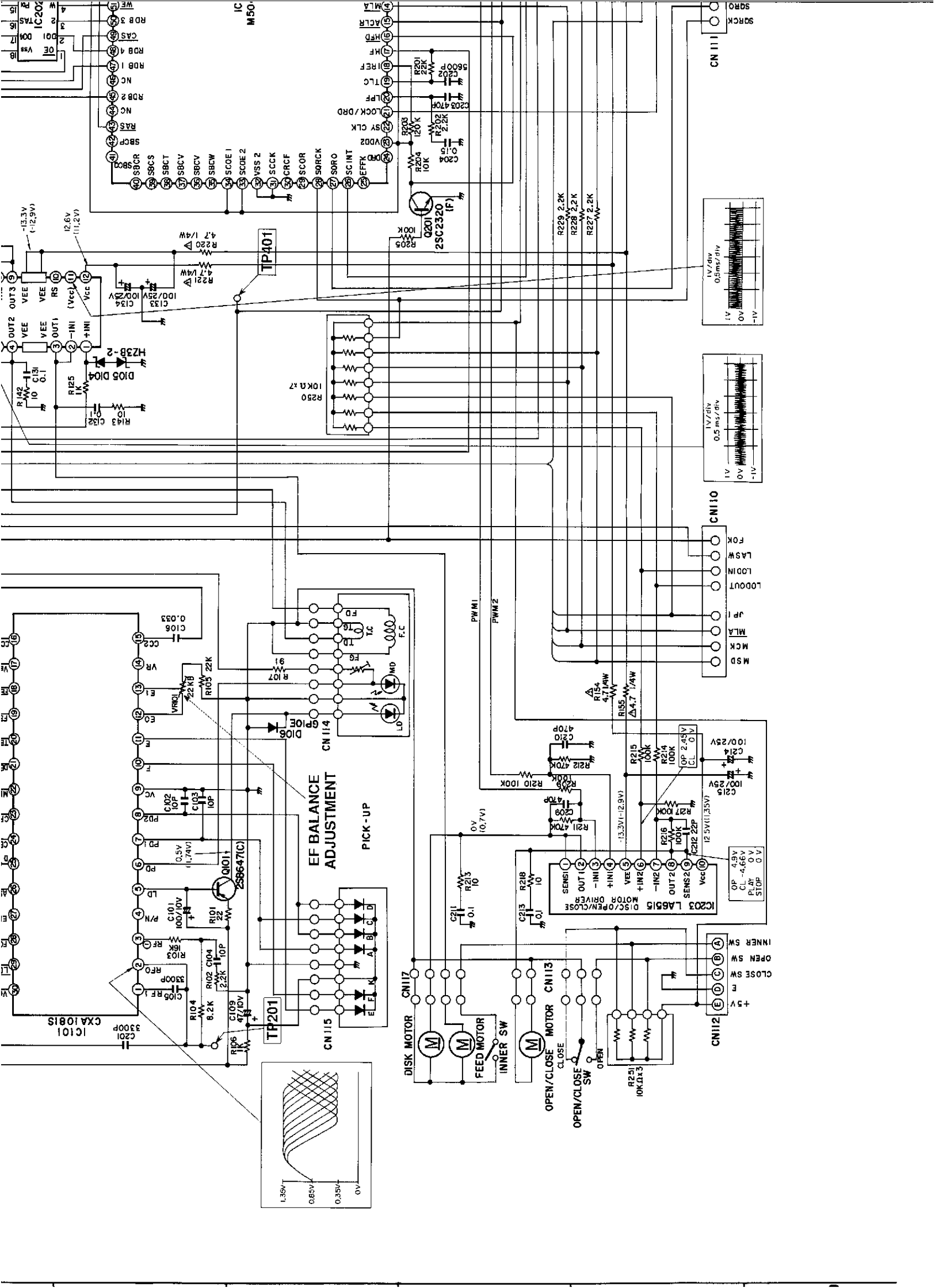

IC101 CXA1081S
 IC201 3300P
 IC203 LA6515
 IC201 74181
 IC202 74185

TP201
 TP401

EF BALANCE
 PICK-UP

DISK MOTOR
 FEED MOTOR
 INNER SW

OPEN/CLOSE MOTOR
 OPEN/CLOSE SW

CN102
 CN103
 CN104
 CN105
 CN106
 CN107
 CN108
 CN109
 CN110
 CN111
 CN112
 CN113
 CN114
 CN115
 CN116
 CN117

MSD
 MCK
 MLA
 JPI
 LODOUT
 LODIN
 LASW
 FOK

1V/div
 0.5ms/div
 1V/div
 0.5ms/div

